

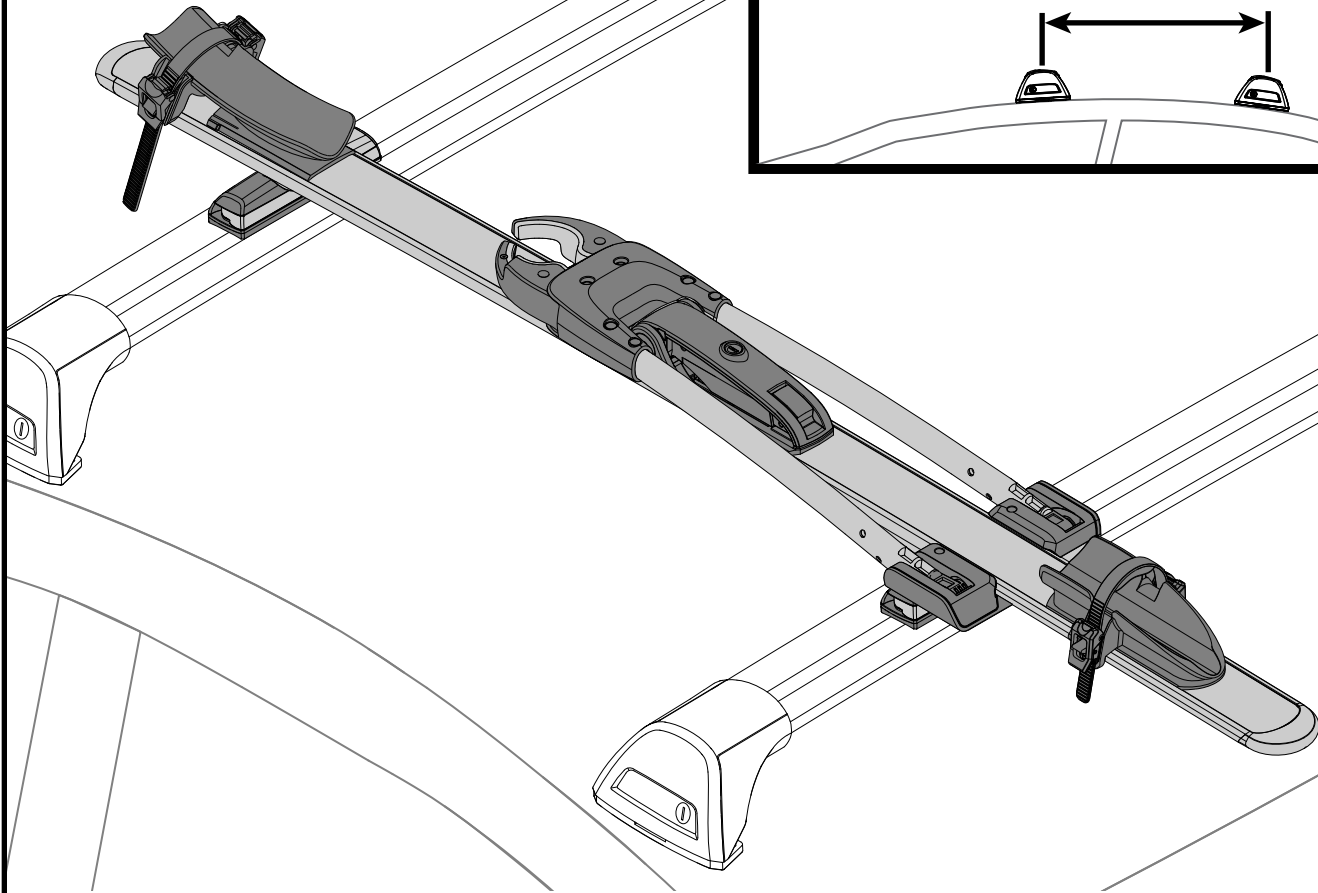

WB201

WHISPBAR™

16" - 18" = 35lbs max (406mm - 457mm = 15.9kg max)
18" - 42" = 44lbs max (458mm - 1066mm = 20kg max)



CONTENTS • CONTENU • CONTENIDO

 KEY (2)
CLÉ (2)
LLAVE (2)

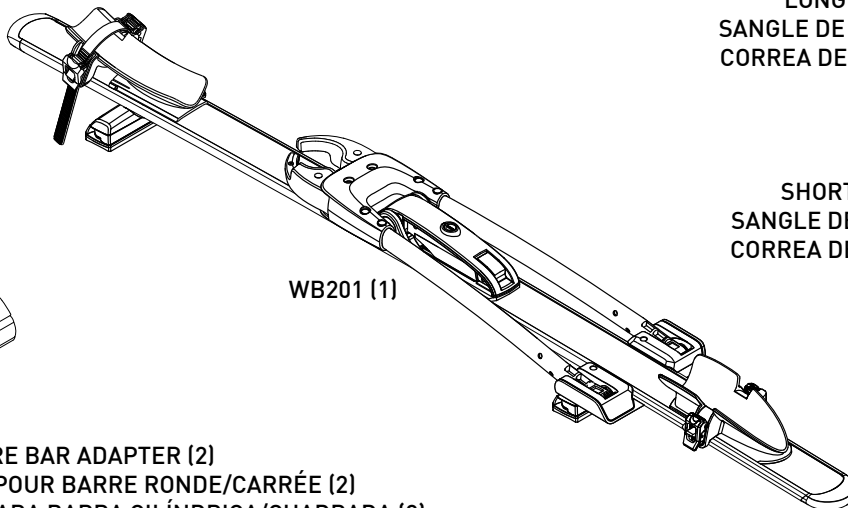

WB201 (1)

LONG WHEEL STRAP (2)
SANGLE DE ROUE LONGUE (2)
CORREA DE RUEDA LARGA (2)

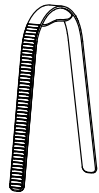

SHORT WHEEL STRAP (2)
SANGLE DE ROUE COURTE (2)
CORREA DE RUEDA CORTA (2)



ROUND/SQUARE BAR ADAPTER (2)
ADAPTATEUR POUR BARRE RONDE/CARRÉE (2)
ADAPTADOR PARA BARRA CILÍNDRICA/CUADRADA (2)

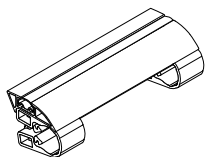

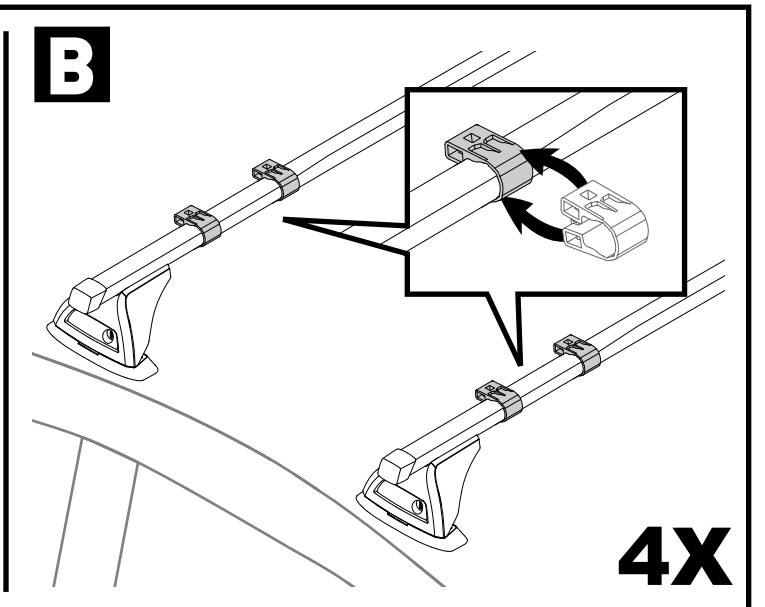
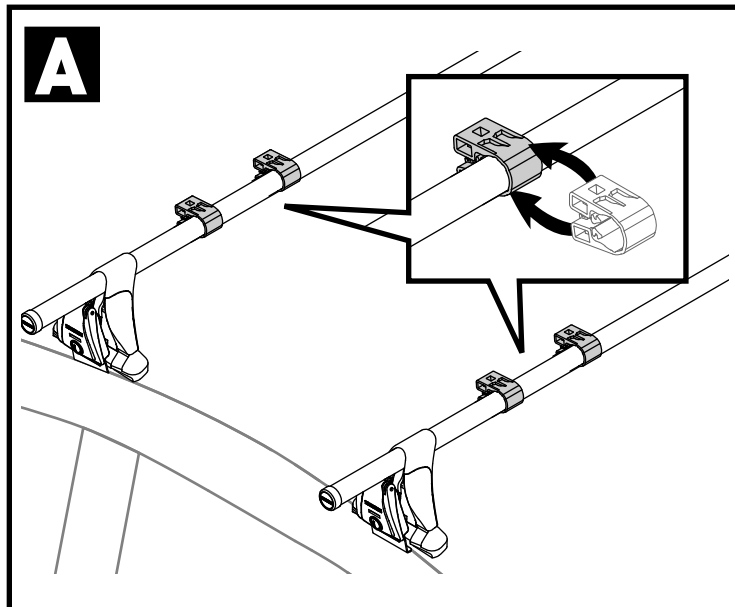
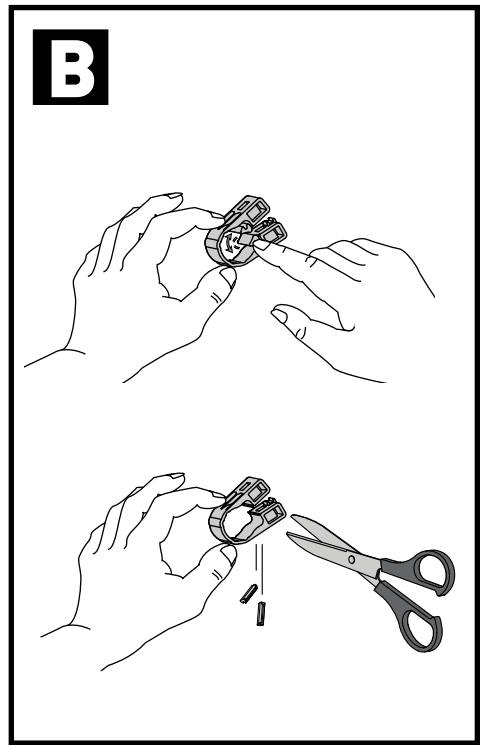
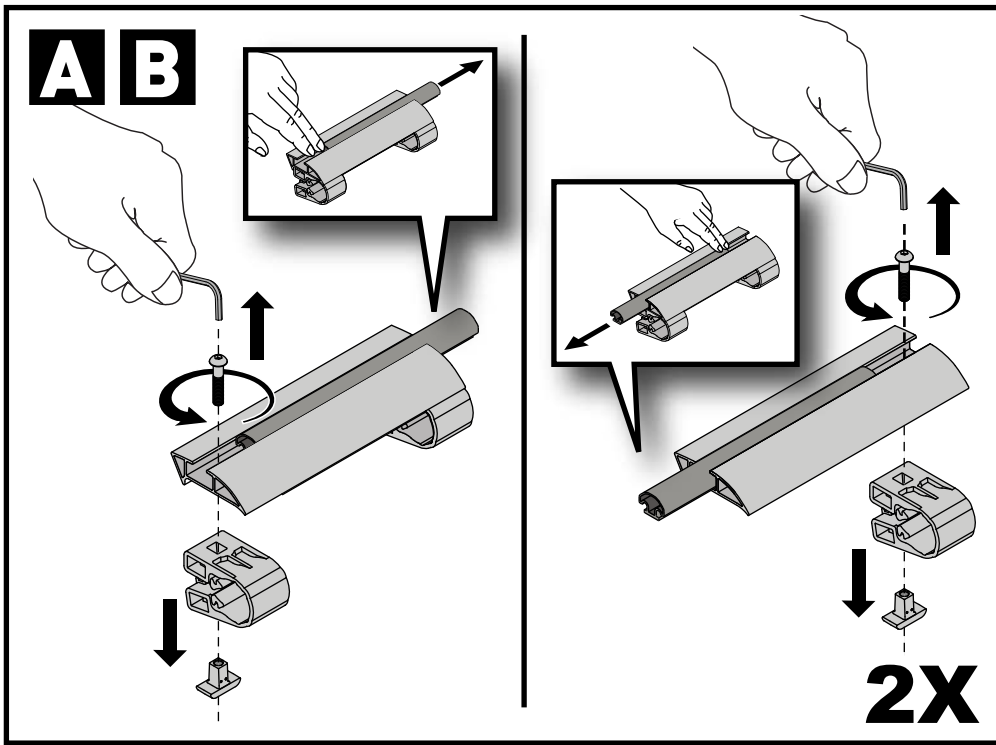
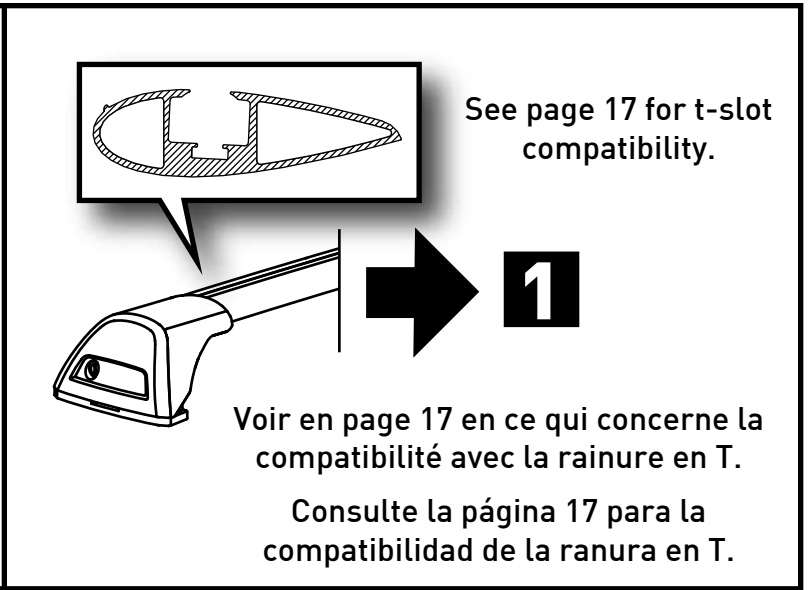
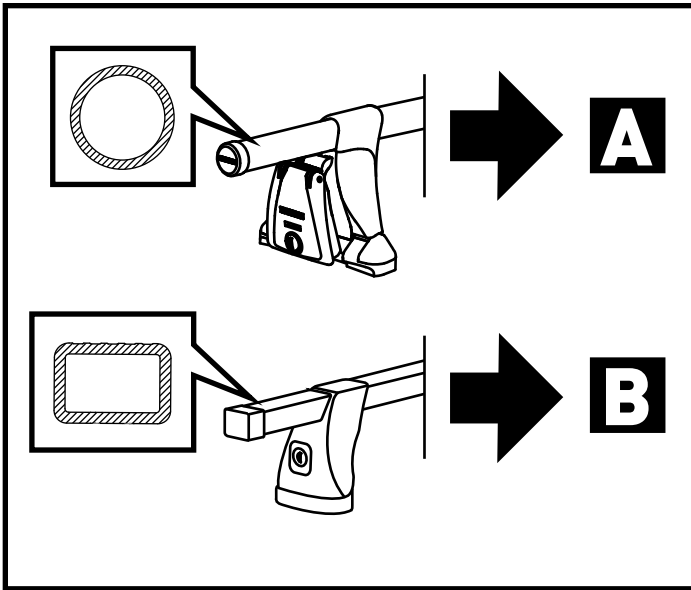

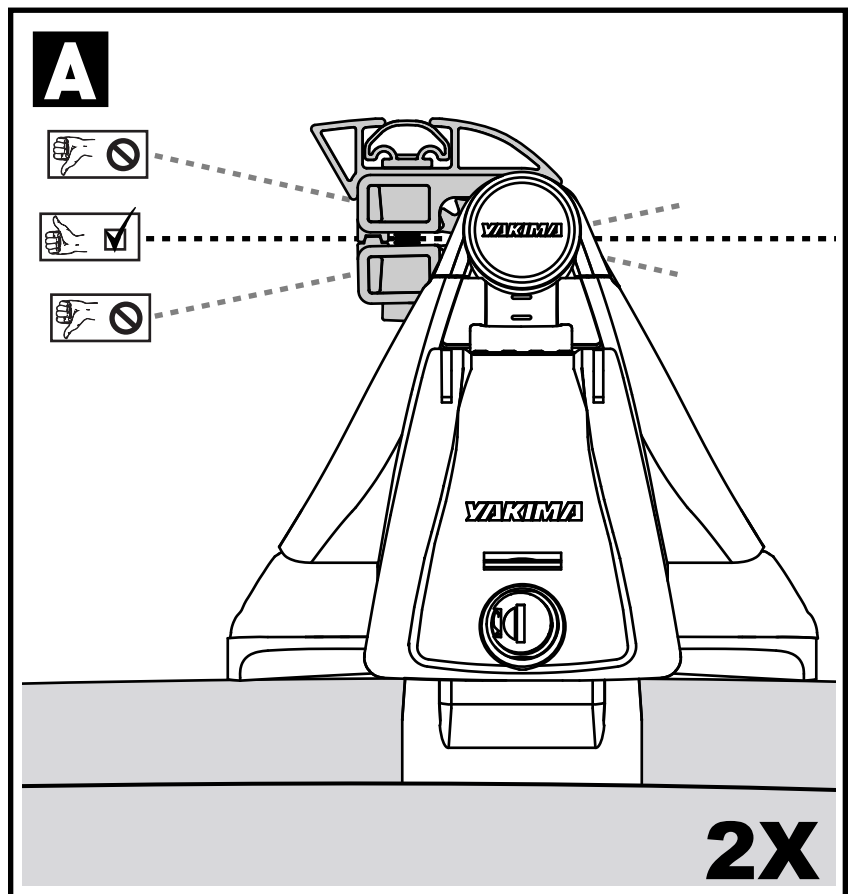
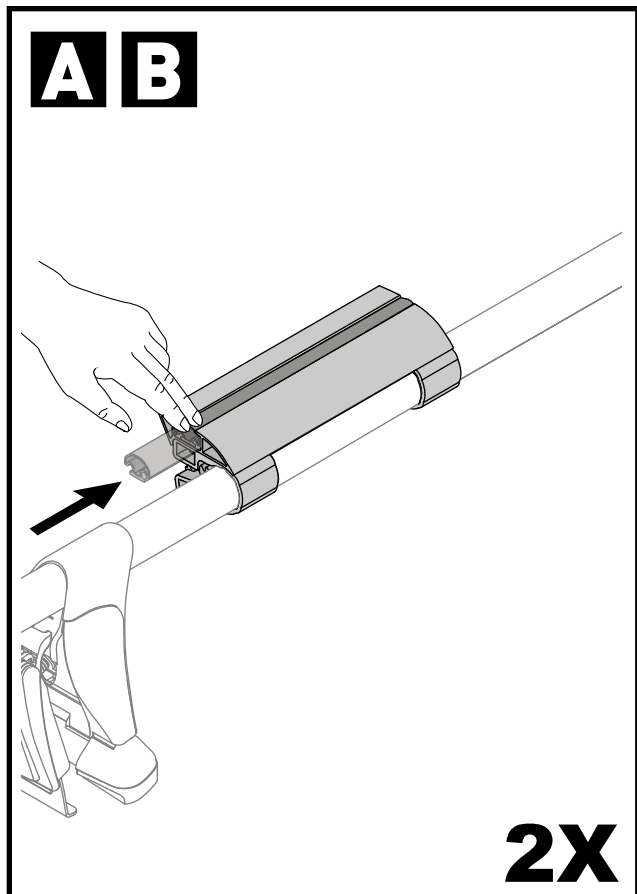
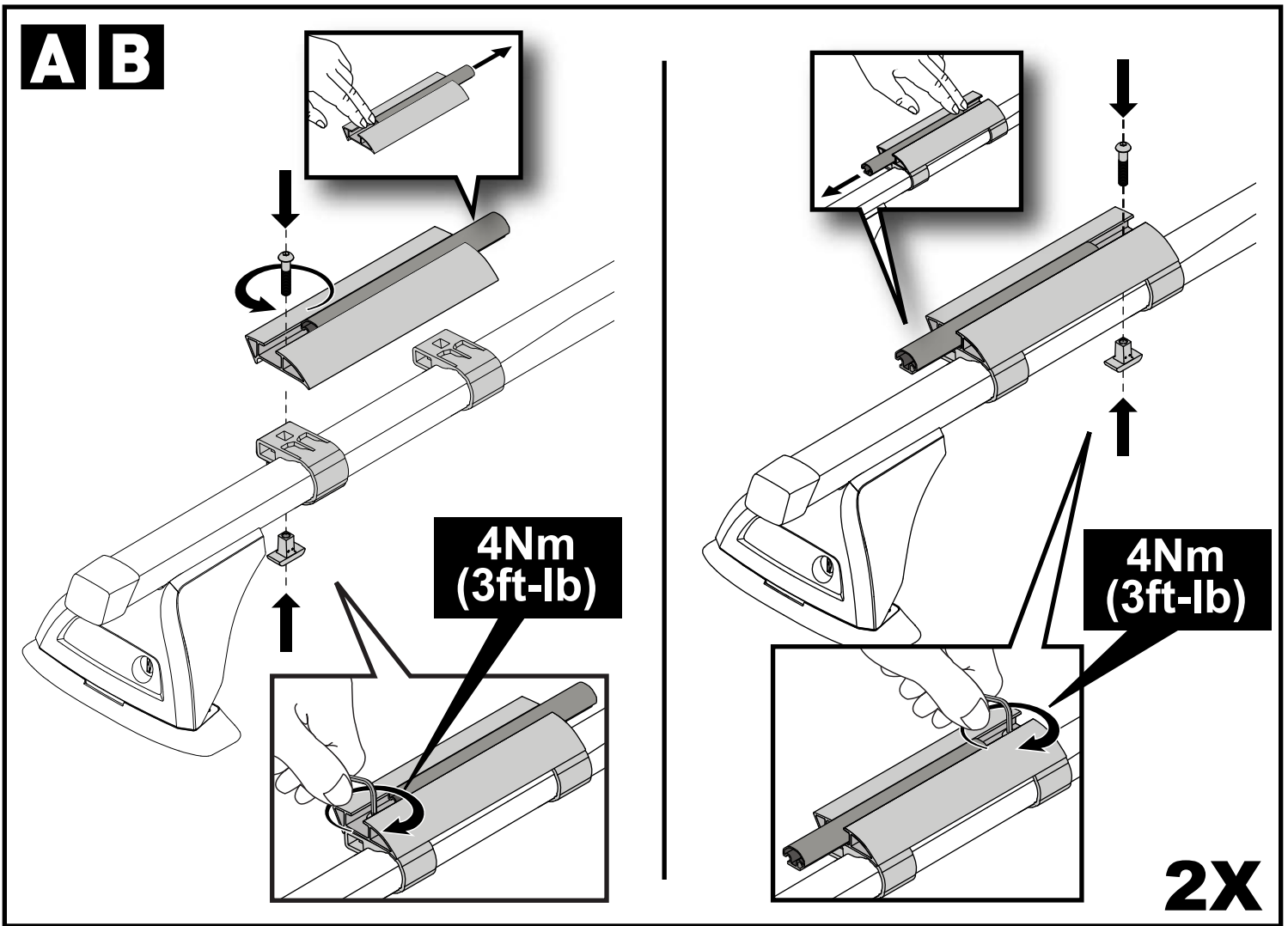

INSTALLATION • MONTAGE • INSTALLATION

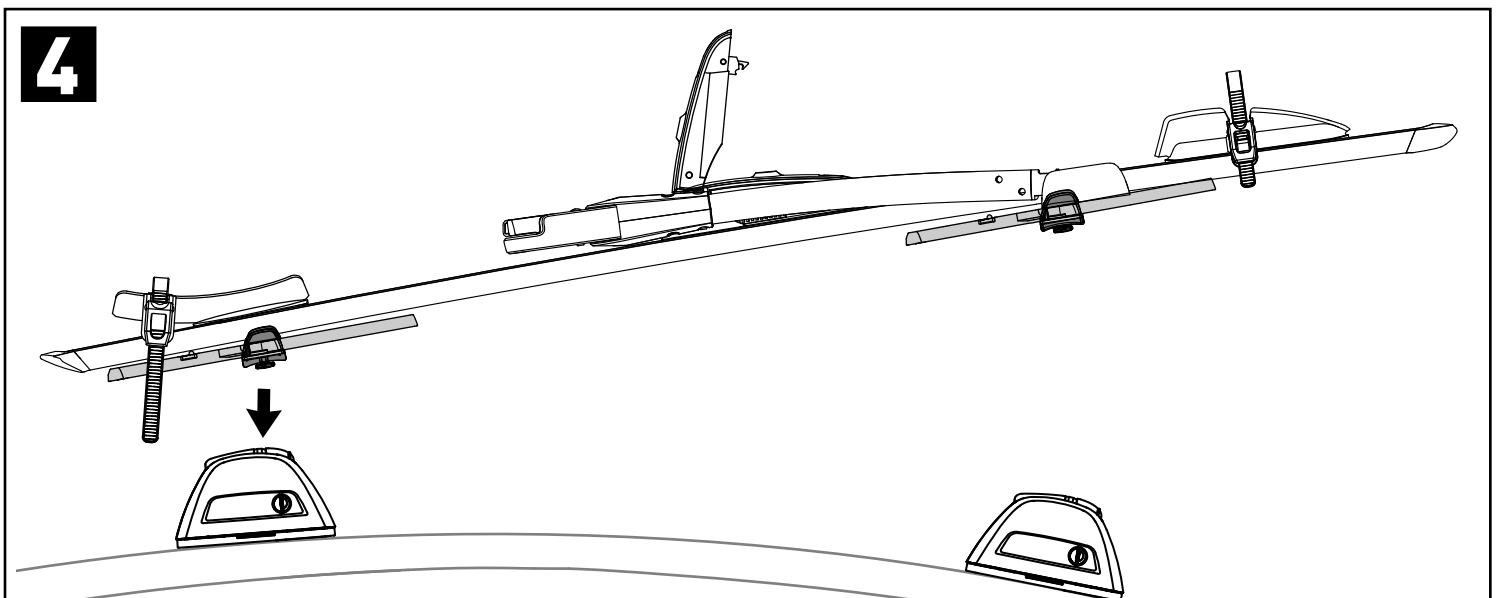
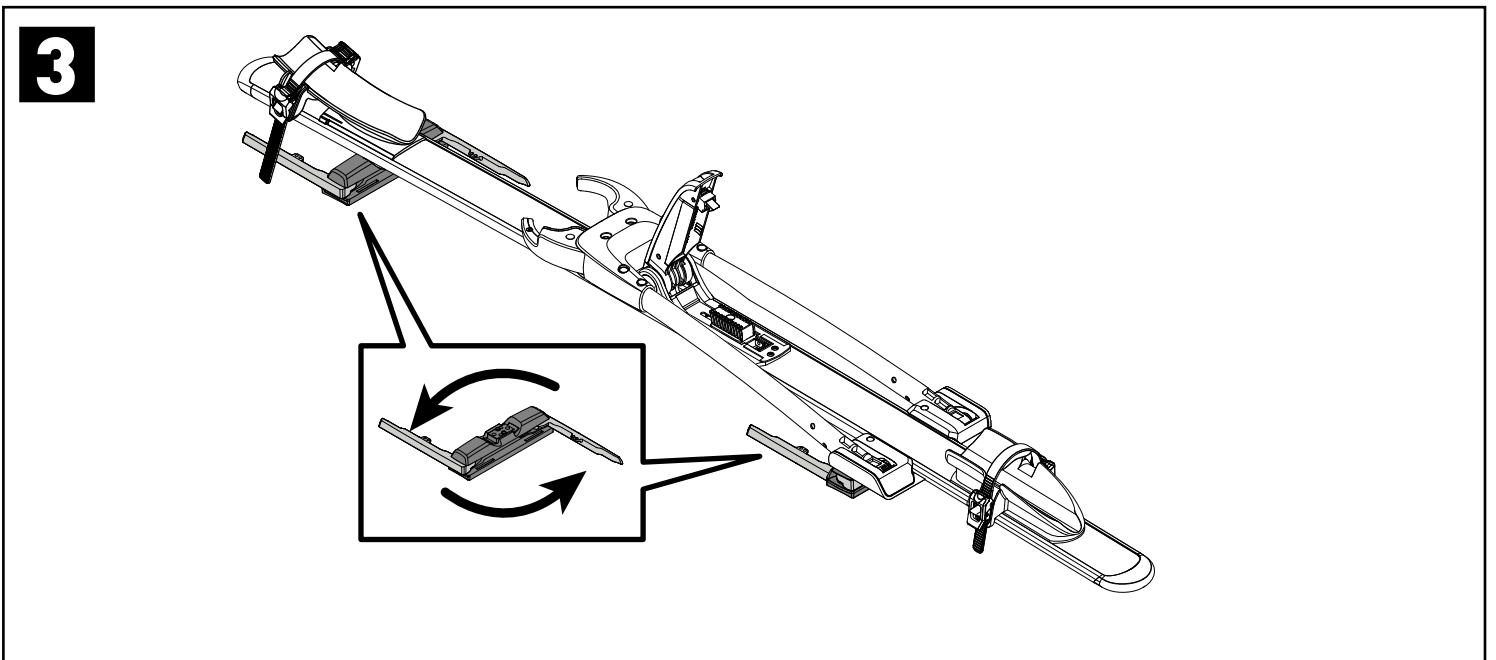
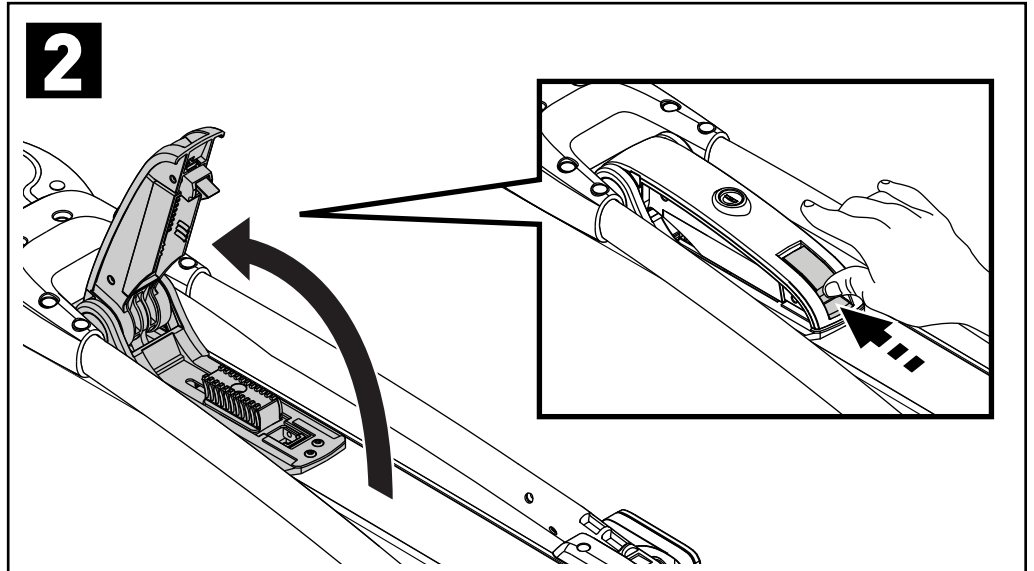
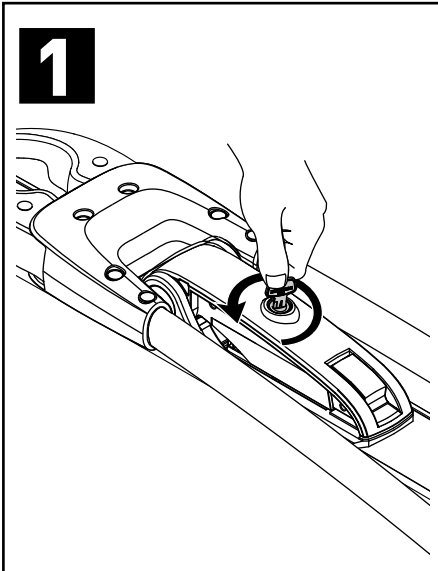

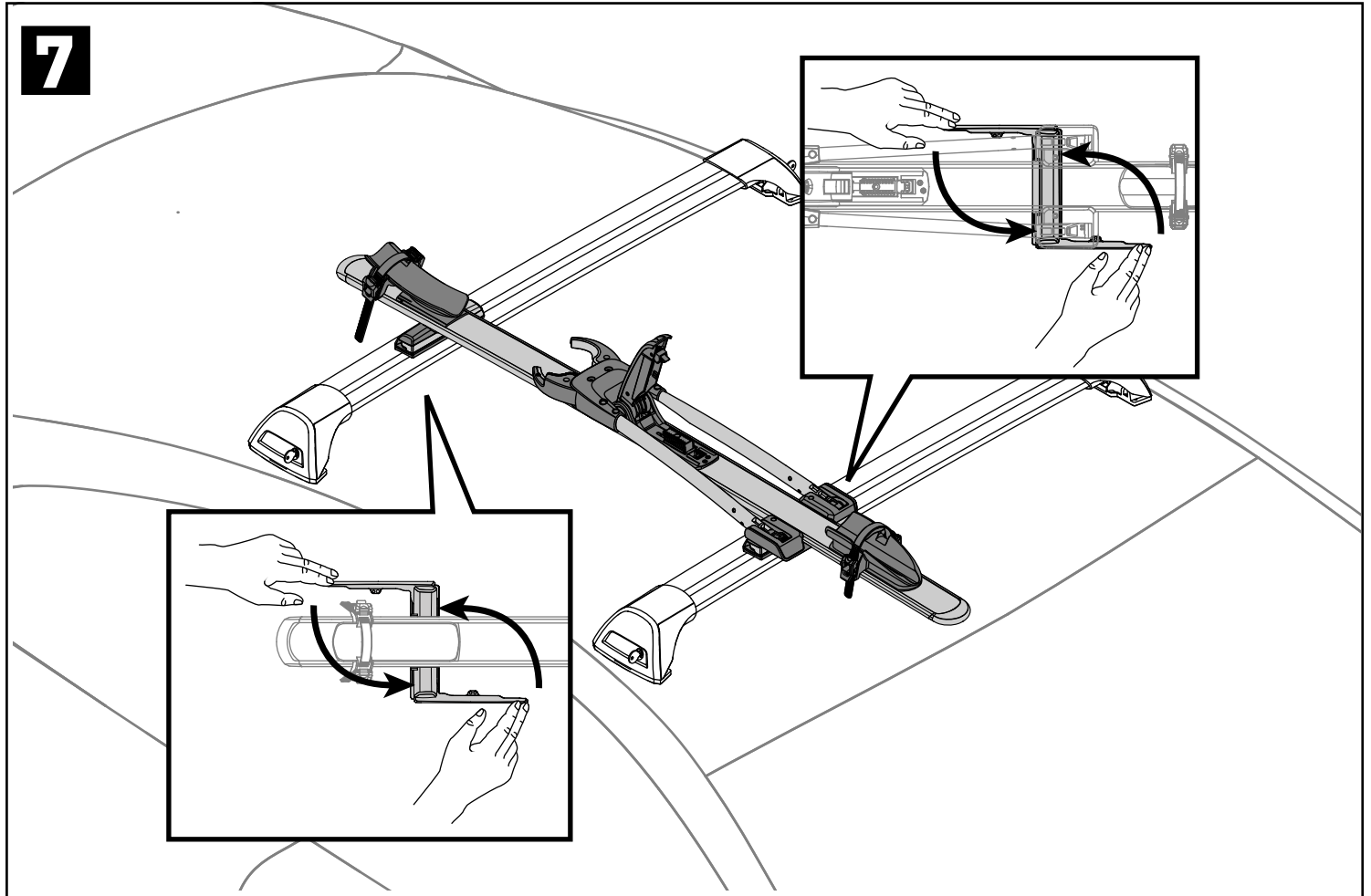
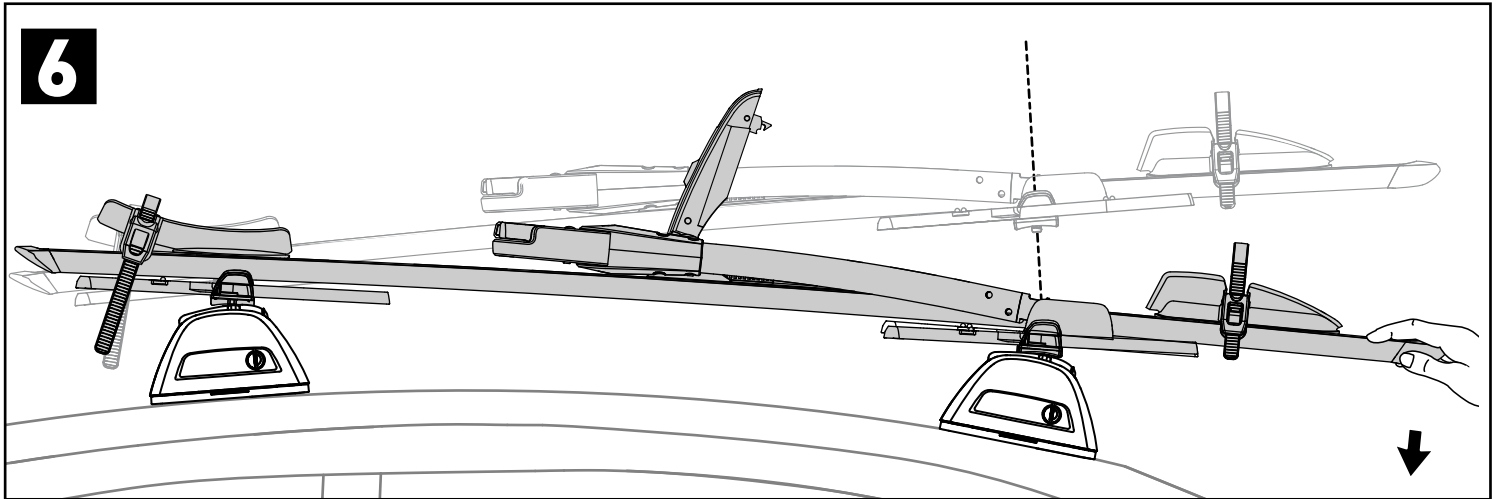
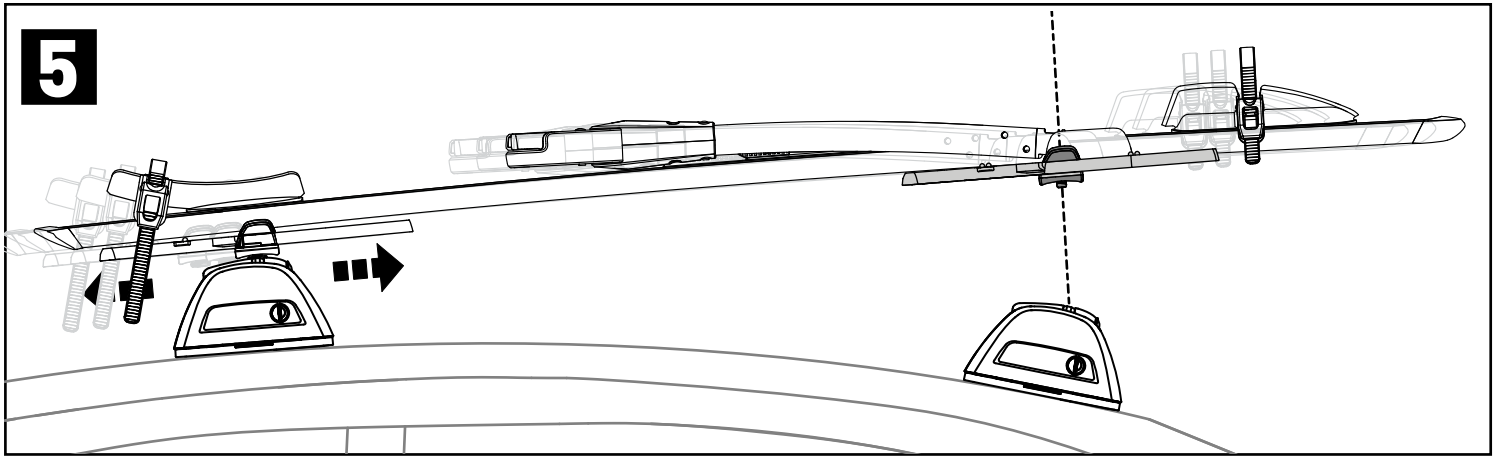

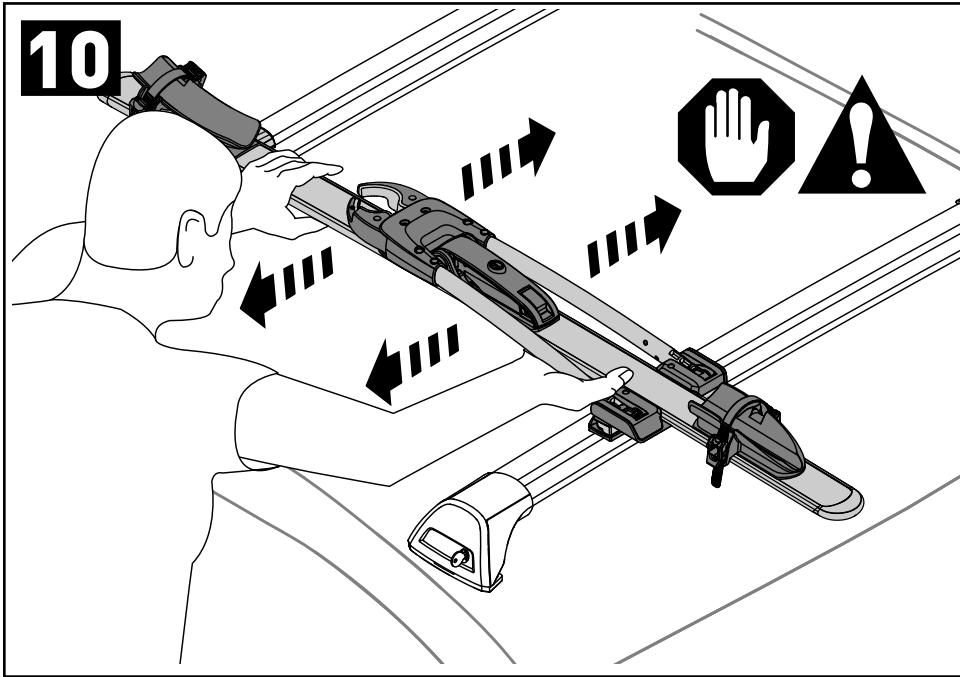
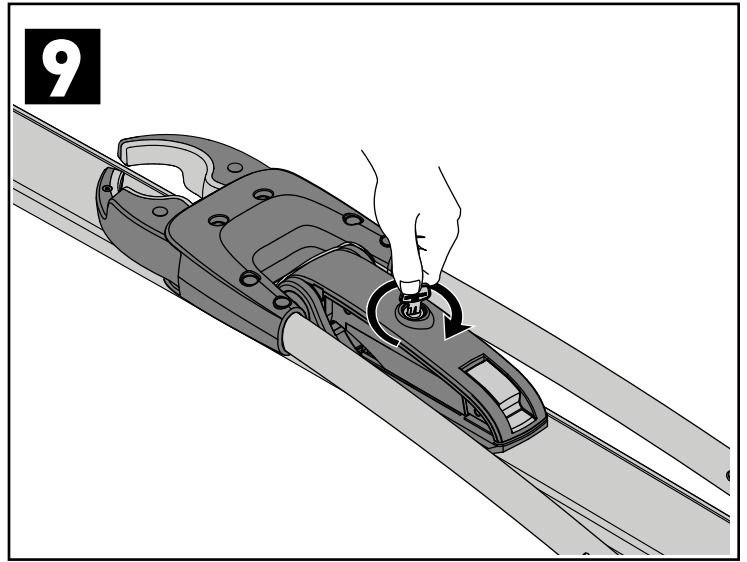
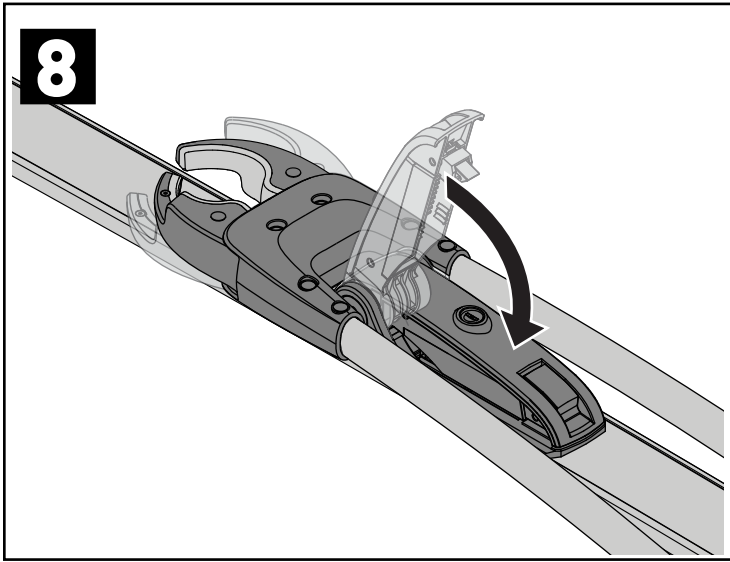

Test the installation. If the carrier moves remove the carrier (see steps 24 through 26) Then repeat steps 2 - 9.

Vérifier la solidité du montage. Si le porte-vélo bouge, l'enlever (voir les opérations 24 à 26), puis répéter les opérations 2 à 9.

Verifique la instalación. Si el portabicicleta se mueve, desmóntelo (consulte las etapas 24 a 26). Luego repita las etapas 2 a 9.

LOADING • CHARGEMENT • CARGA

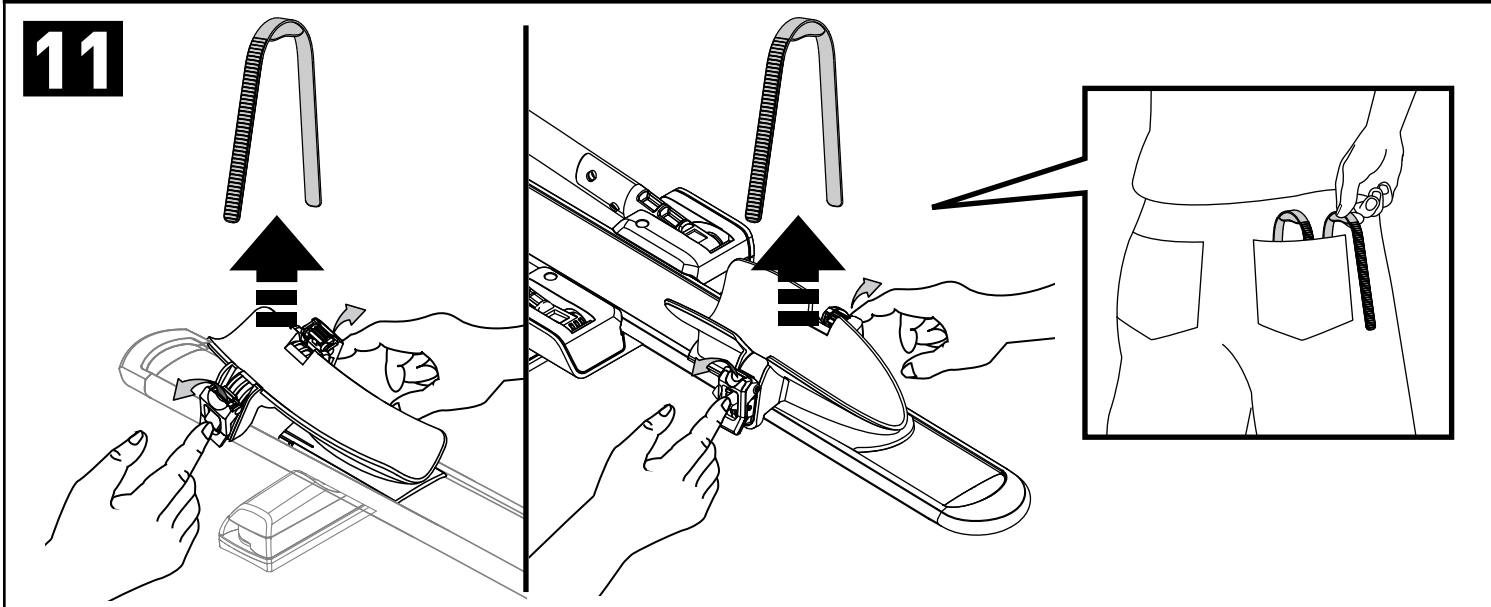

12

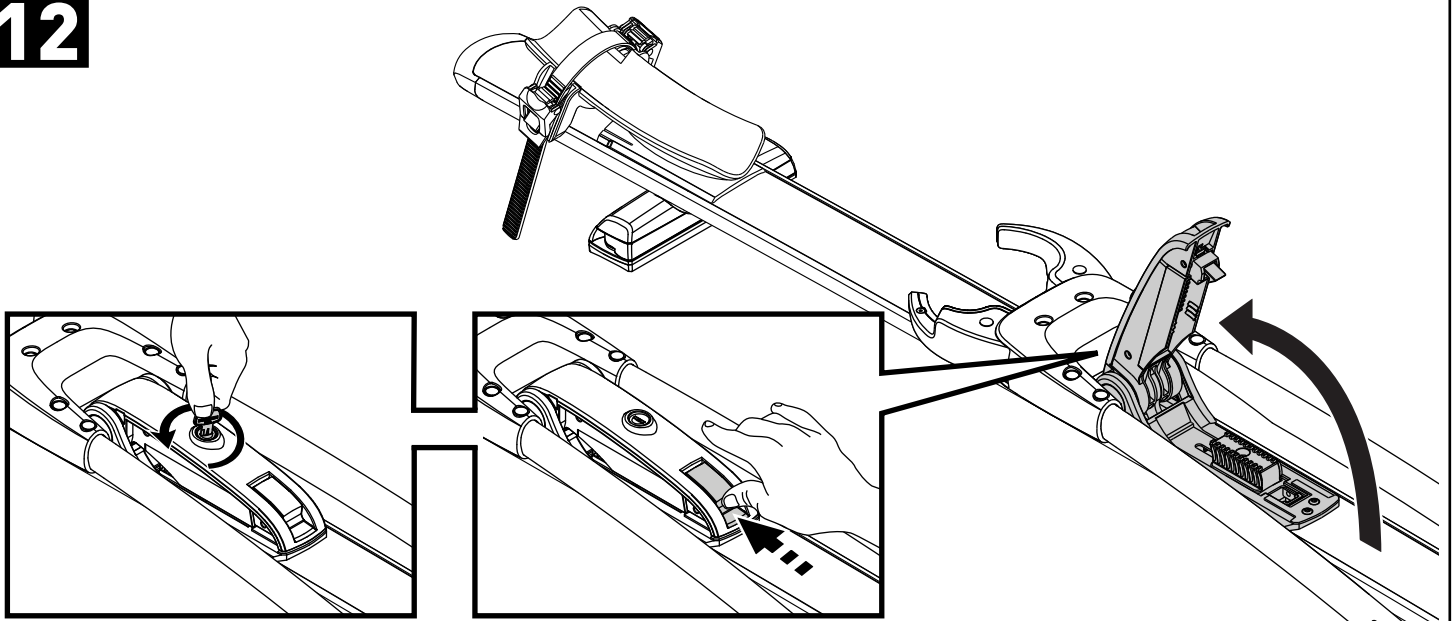

13

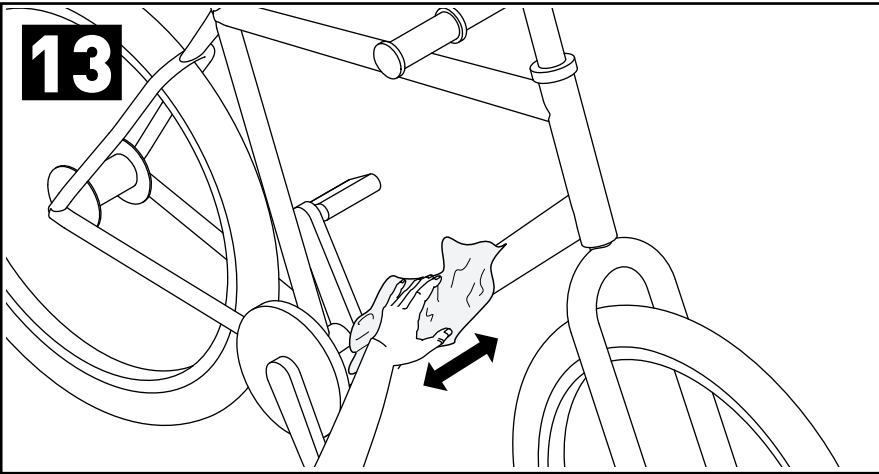

14

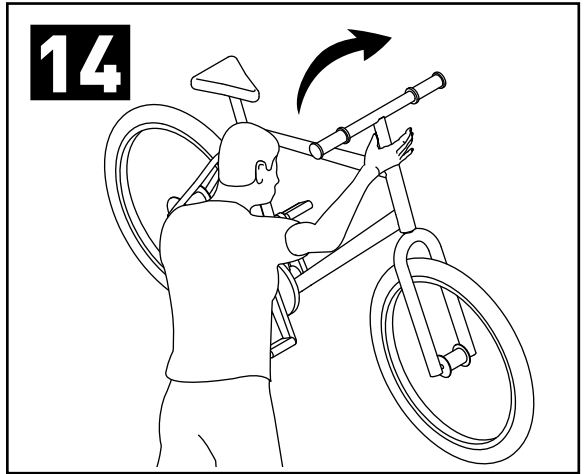

15

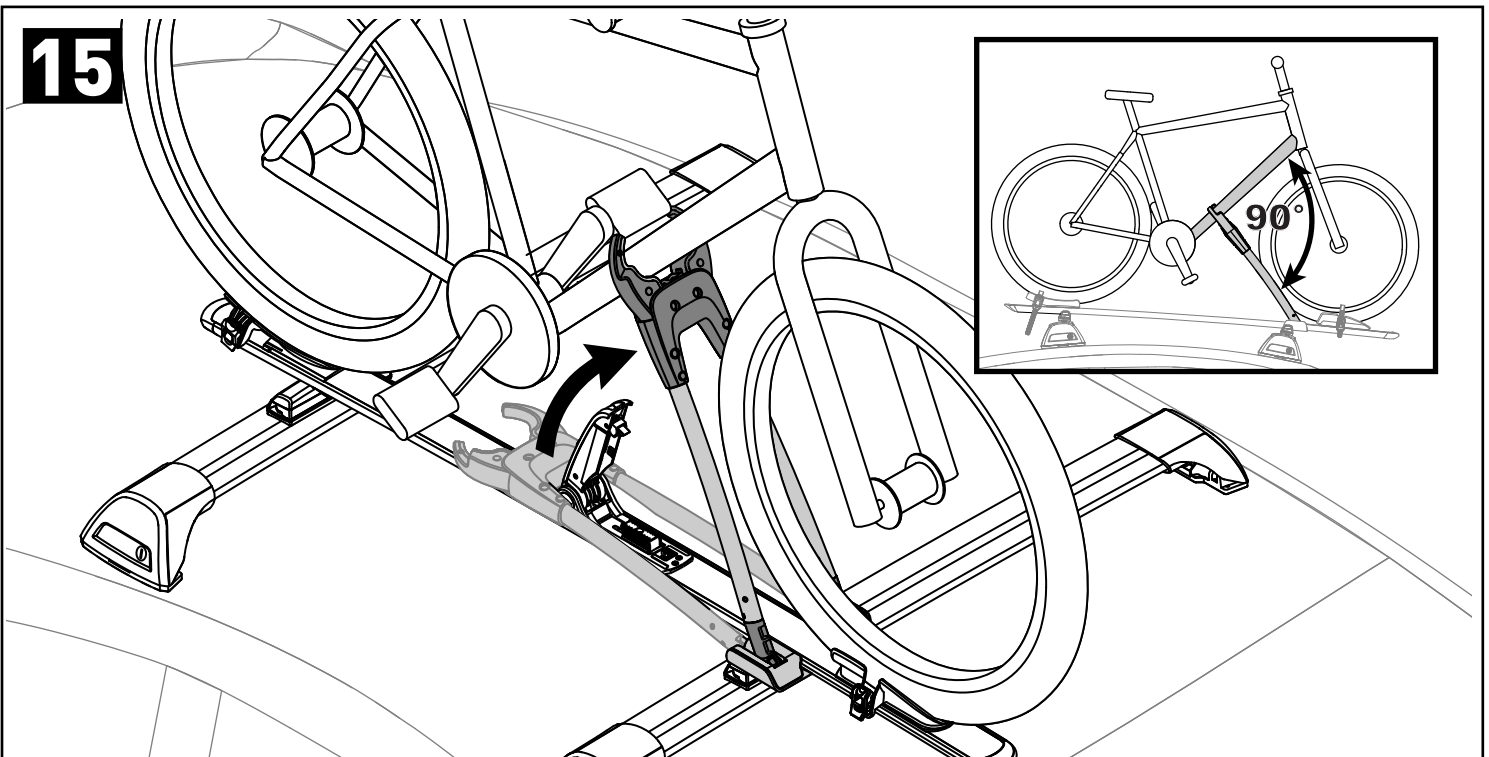

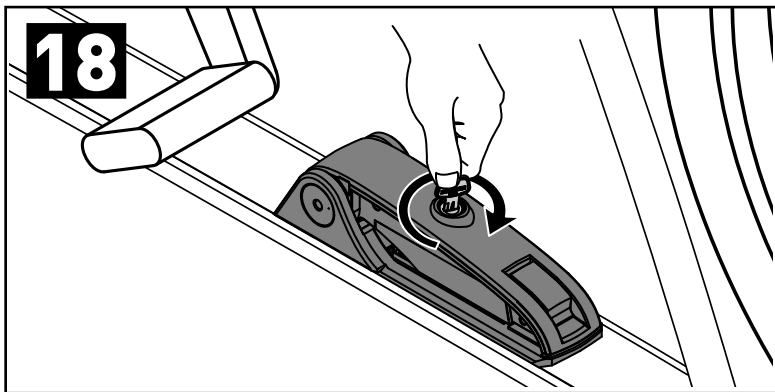
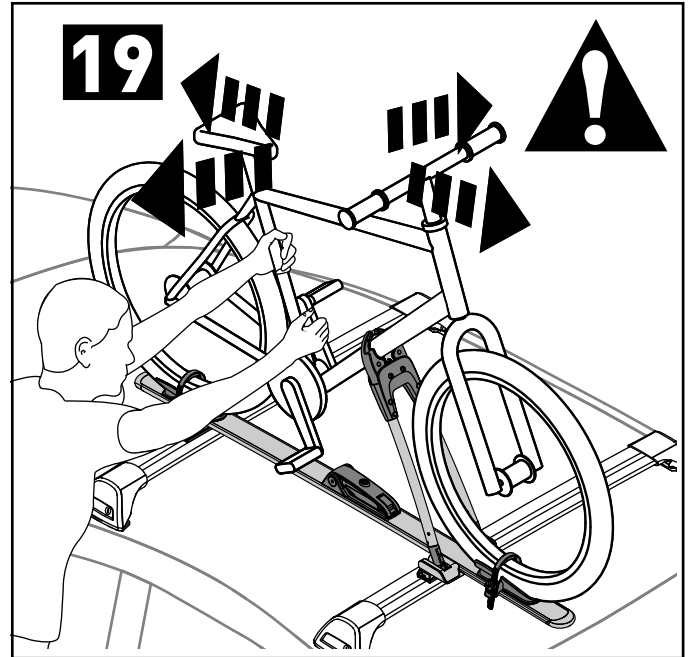
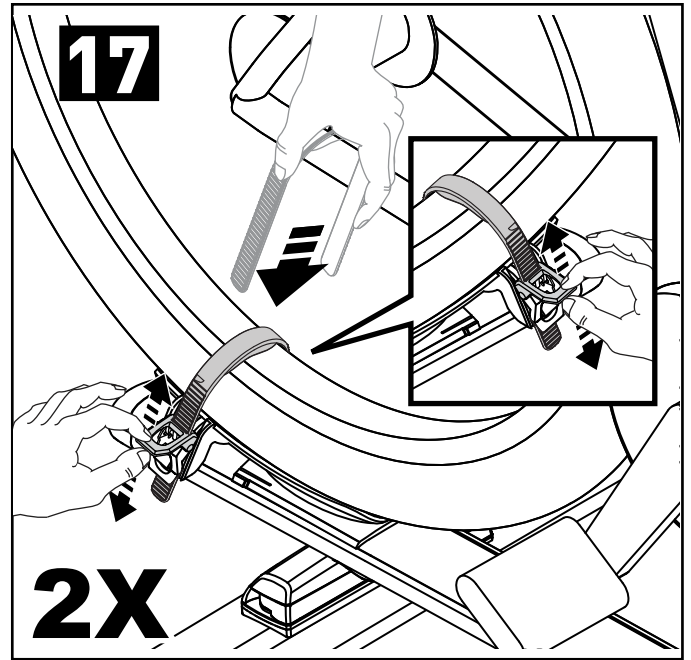
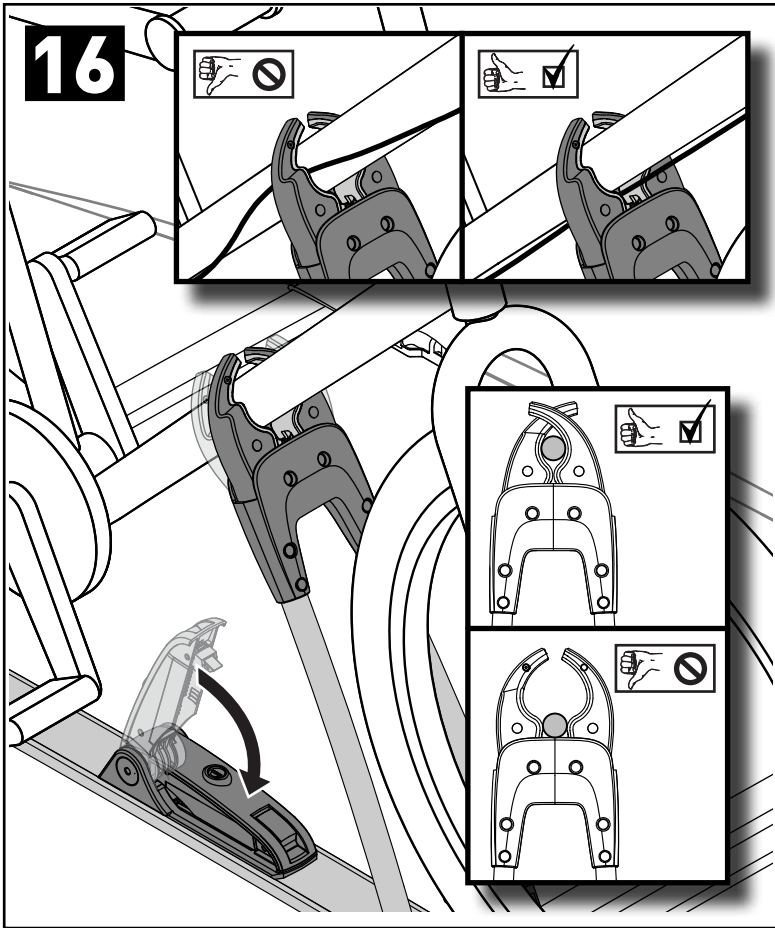

UNLOADING • DÉCHARGEMENT • DESCARGA

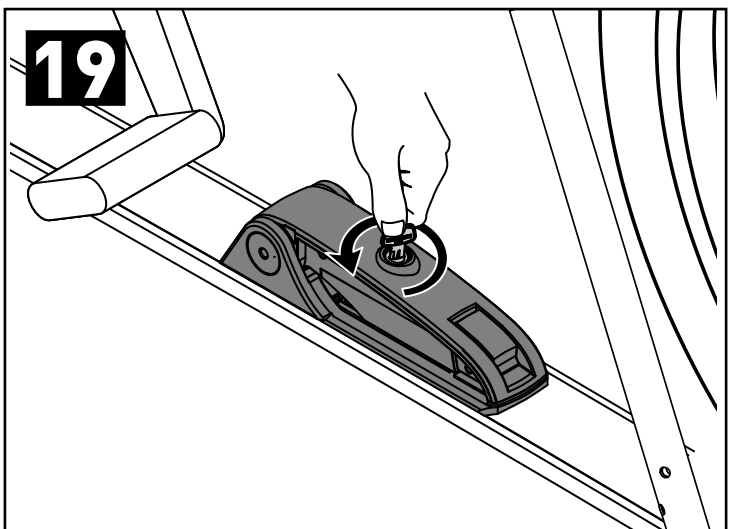
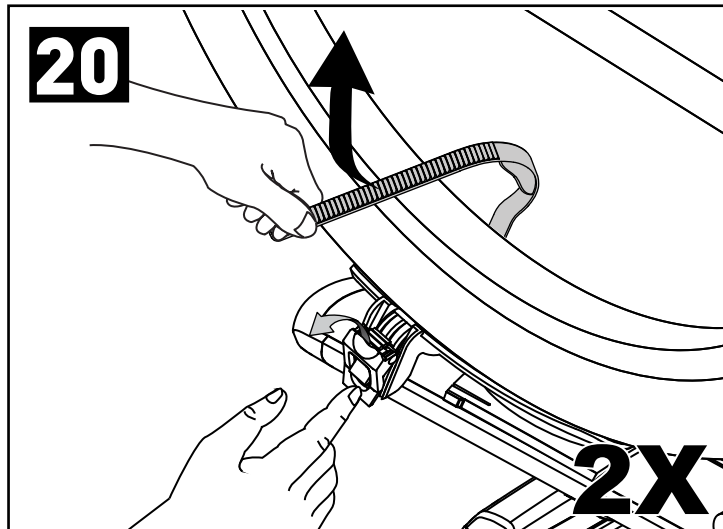

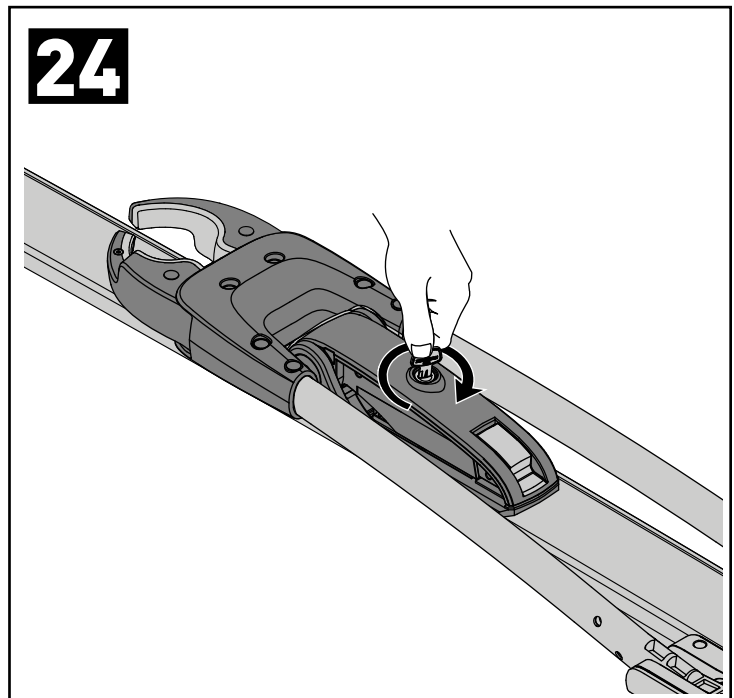
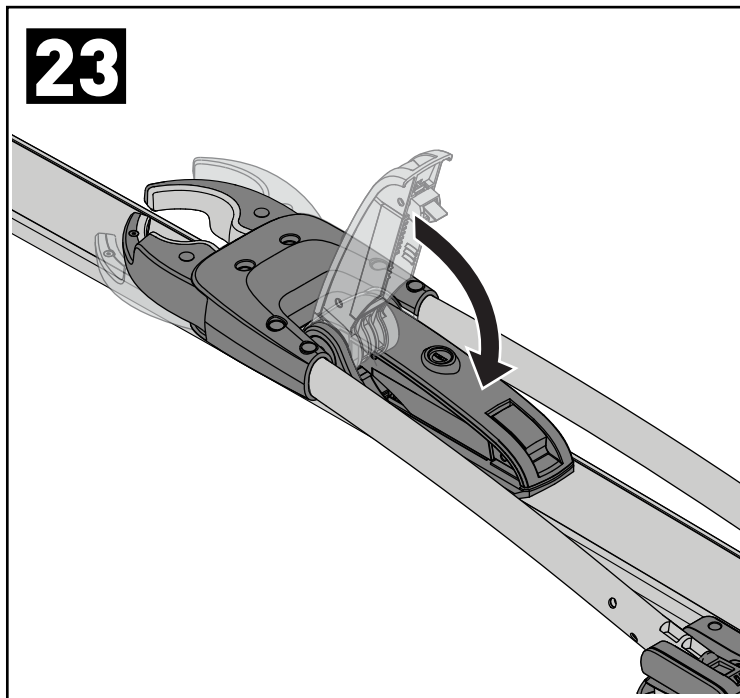
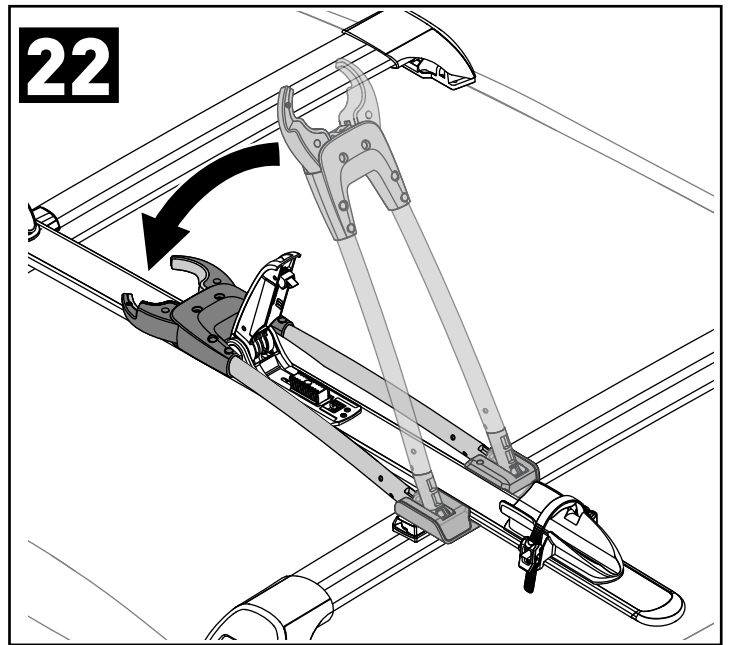
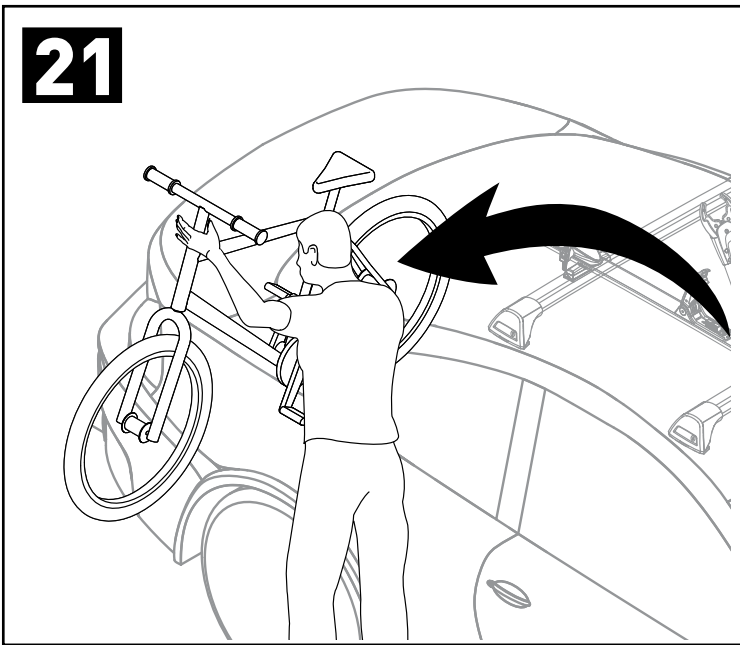
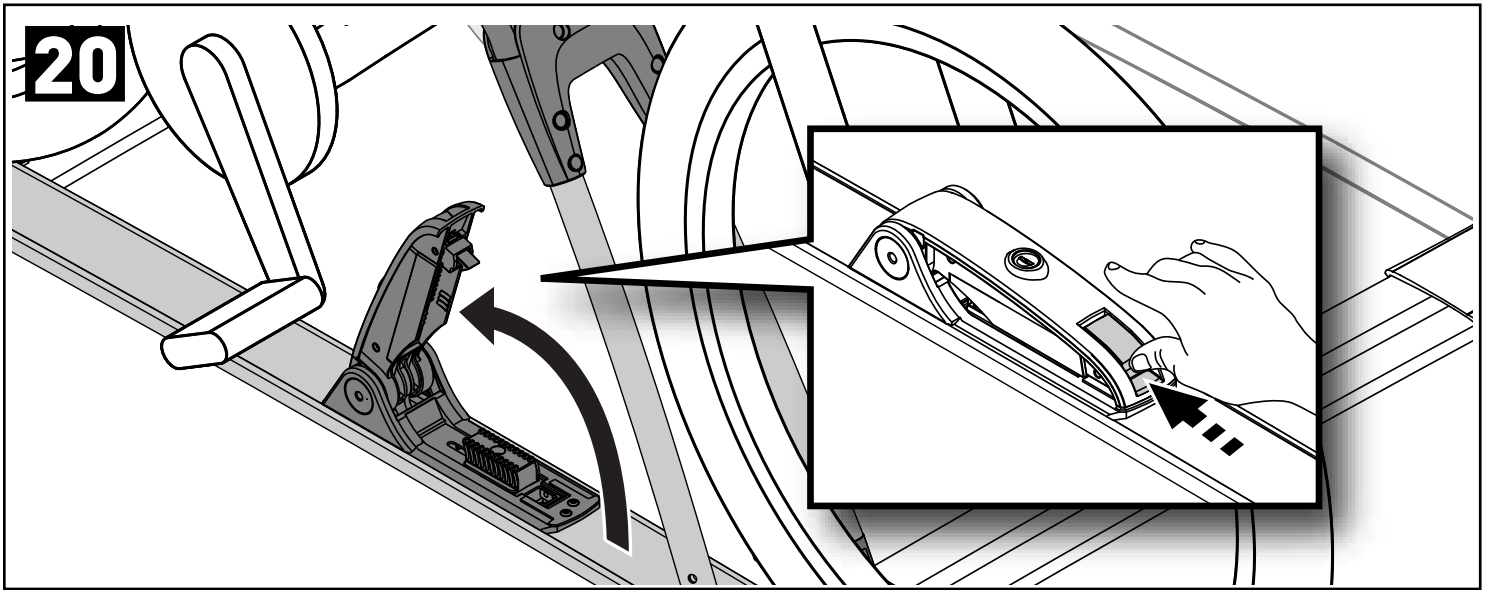

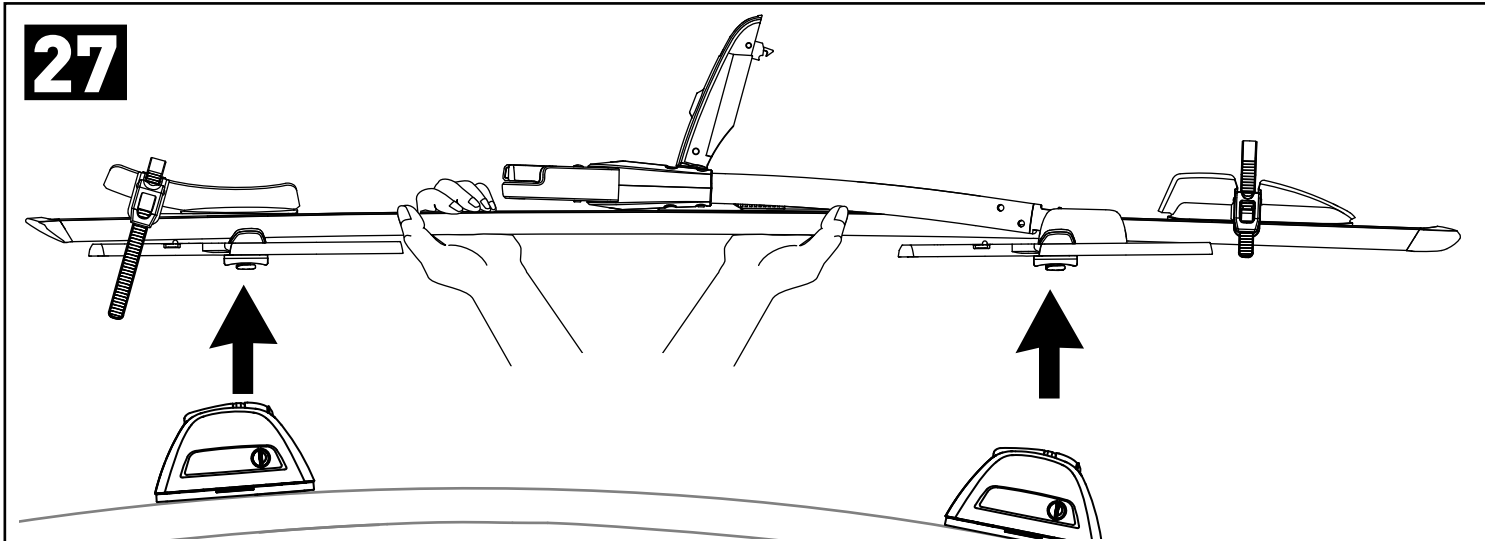
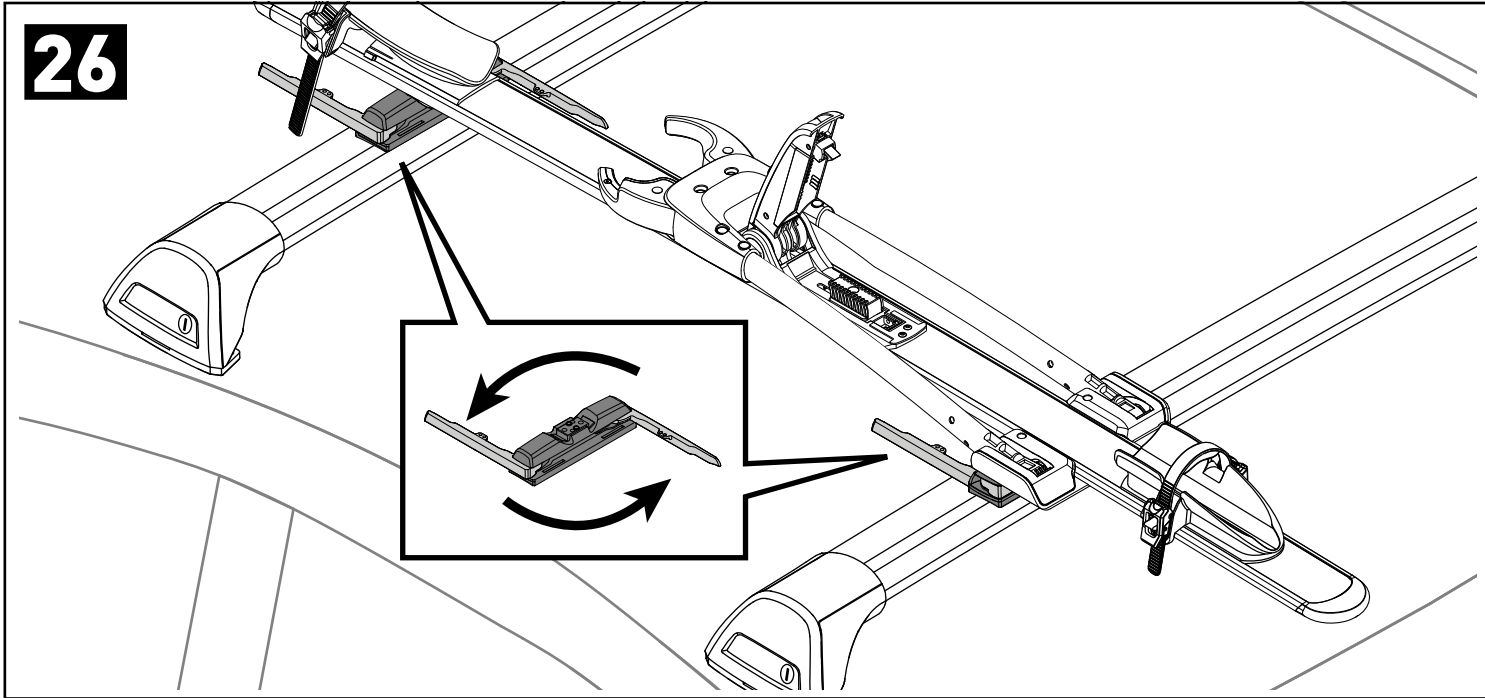
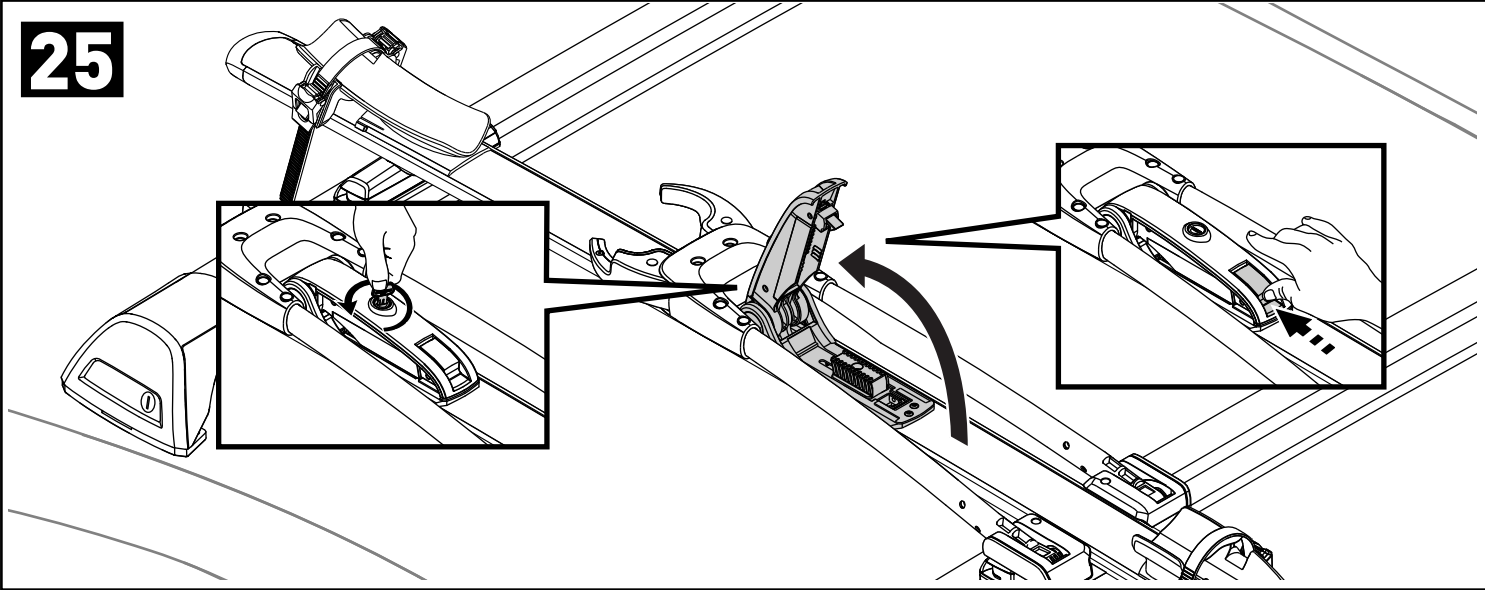

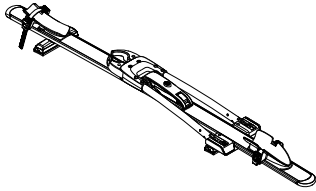
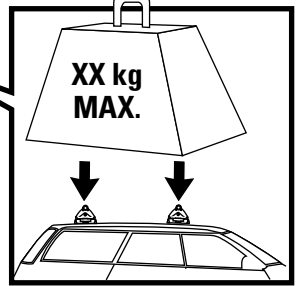
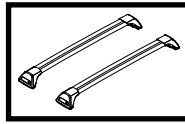
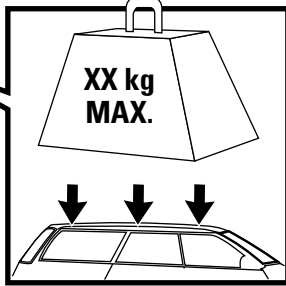
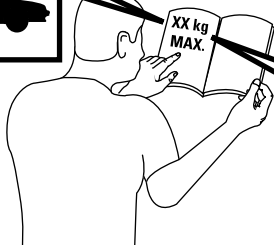
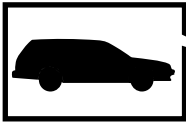

16" - 18" = 35lbs max.
 (406mm - 457mm = 15.9kg max.)
 18" - 42" = 44lbs max.
 (458mm-1066mm = 20kg max.)

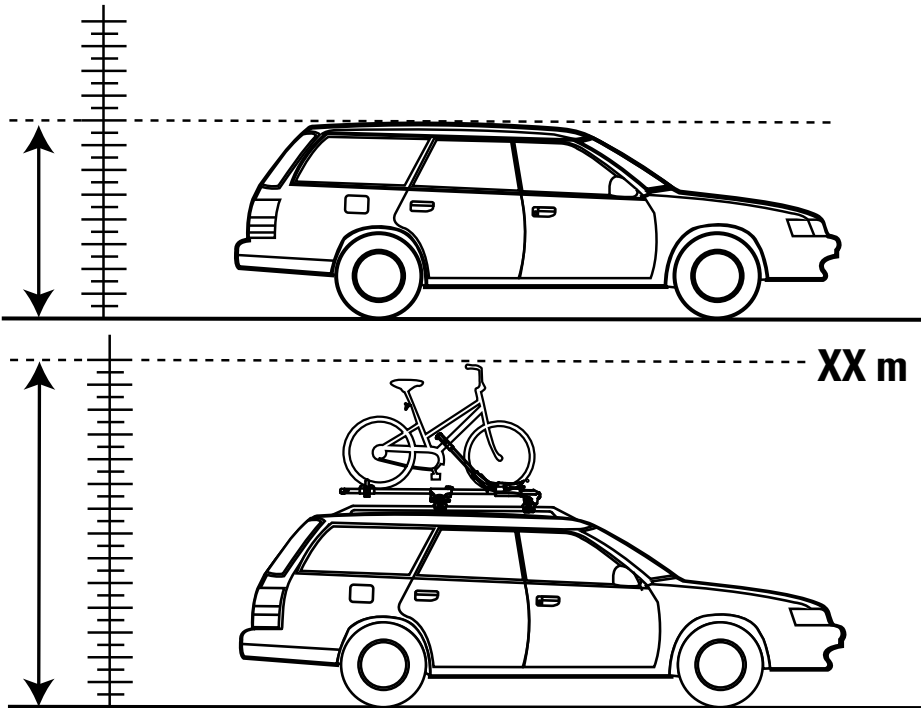

**Record Height Here.
 Noter la hauteur ici.
 Escriba aquí la altura.**

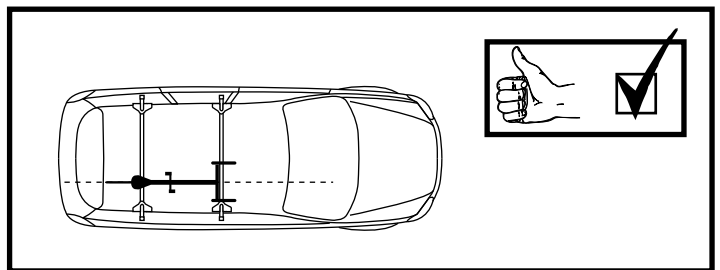
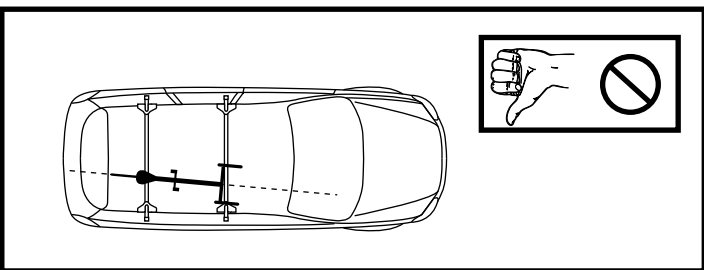
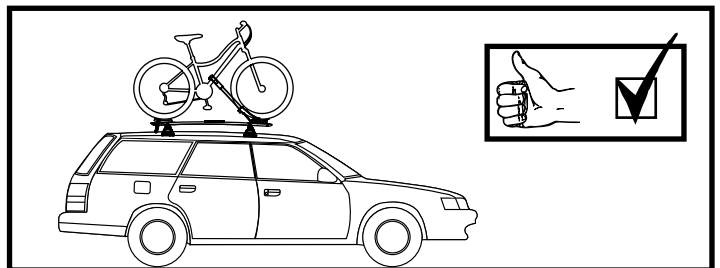
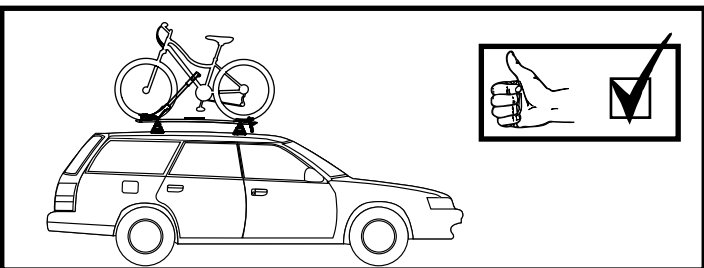

WARNINGS • AVERTISSEMENTS • ADVERTENCIAS

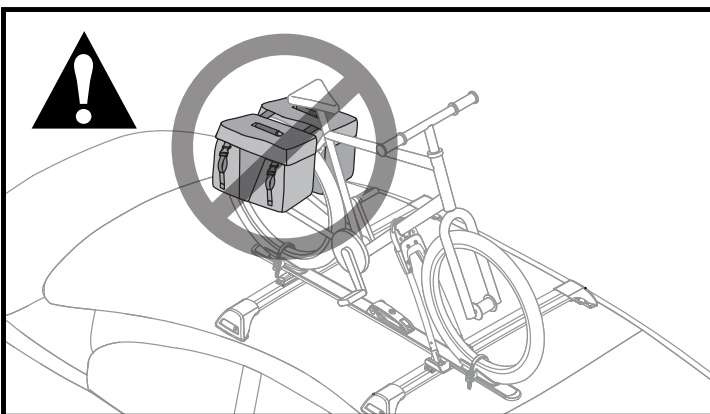
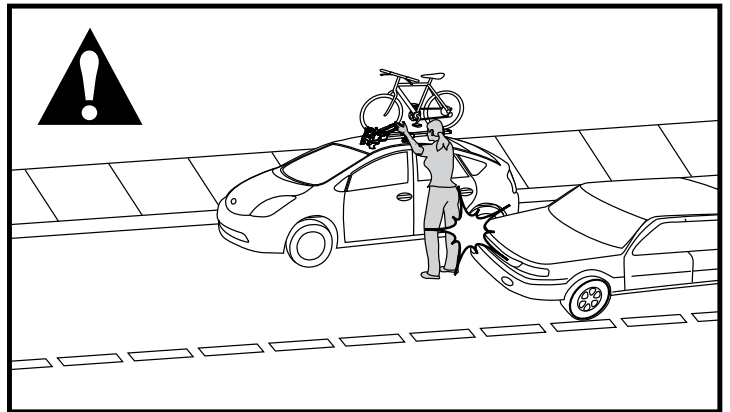
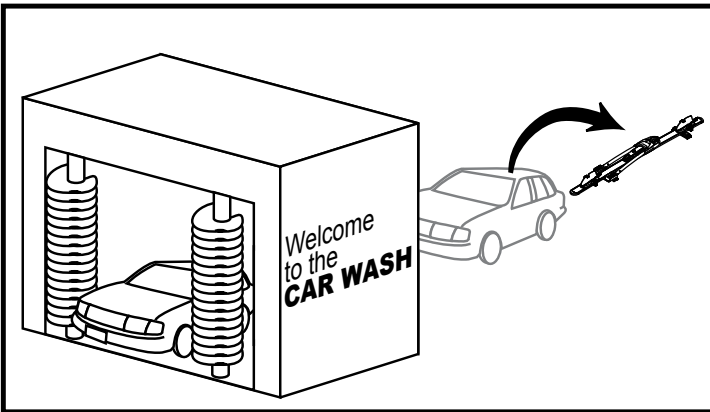
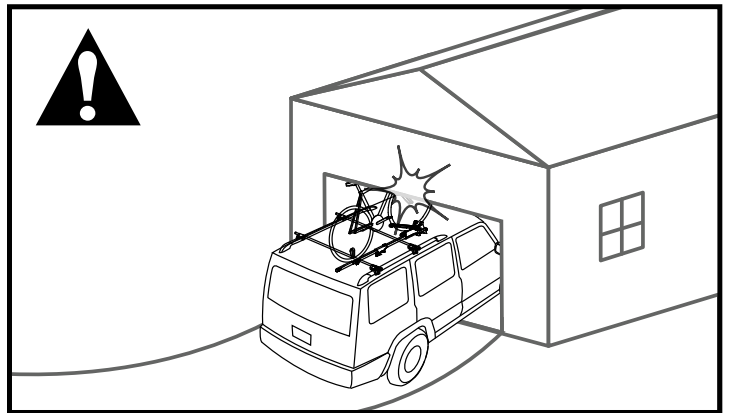
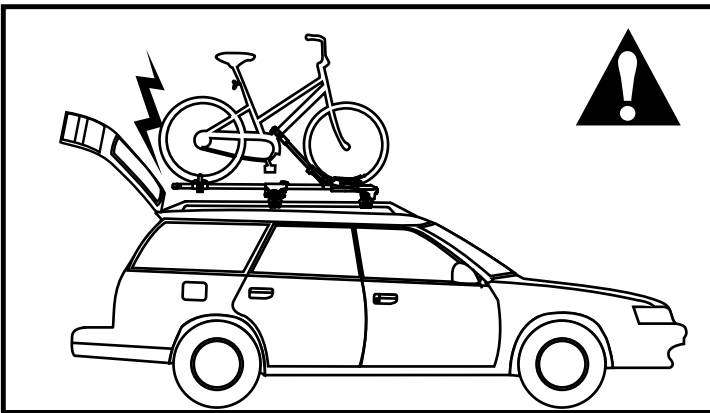
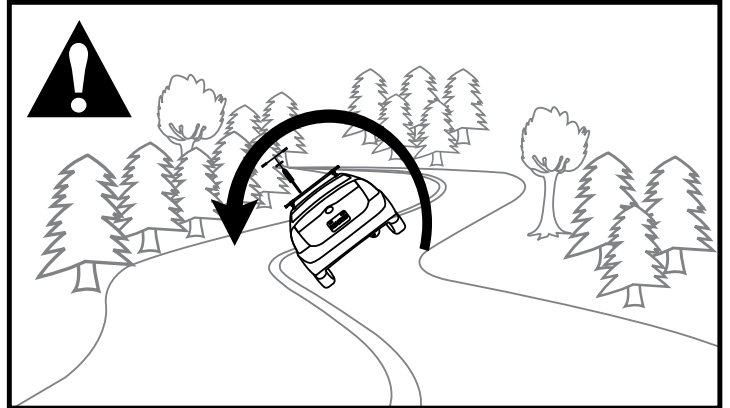
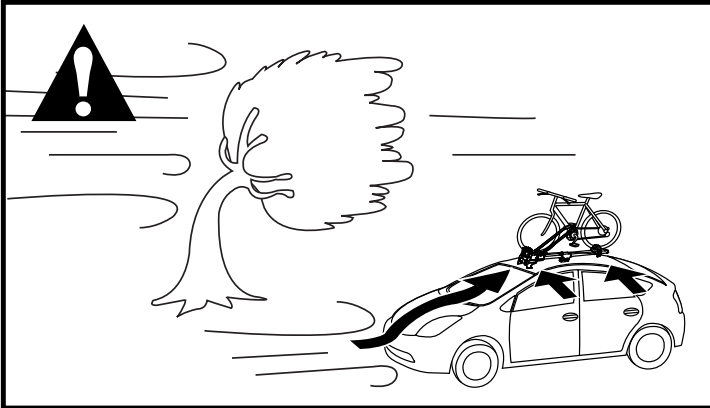

EN IMPORTANT WARNINGS

Rack Installation

Inadequately secured loads and incorrectly mounted roof racks and accessory racks can come loose during travel and cause serious accidents! Therefore, installation, handling and use must be carried out in accordance with product and vehicle instructions.

In addition to these instructions, review the mounting instructions for the roof rack and the operating instructions of the vehicle.

These instructions should be kept together with the vehicle's operating instructions and carried in the vehicle when in use and en route.

For your own safety, you should only use tested (e.g. GS-tested) roof racks that are authorized for use with your vehicle.

Check attachment hardware and load for tight fit and function:

- Before the start of any journey.
- After driving a short distance following rack or load install.
- At regular intervals on longer journeys.
- More frequently on rough terrain.
- After interruption of a journey during which the vehicle was left unsupervised. (check for damage due to outside intervention)

Rack Loading

Do not exceed the maximum load specified for the roof rack, accessory rack or the maximum load recommended by the vehicle manufacturer.

Max Roof Load = weight of roof rack + weight of accessory racks + weight of load.

Bicycle parts, such as handlebars or pedals, shall not project beyond the contours of the vehicles.

All loose and removable parts, must be removed from bicycles prior to loading onto bike rack.

Do not transport bicycles with attached baby seats, panniers, wheel covers, full bike covers or motors.

Do not carry tandem or recumbent bicycles.

Vehicle Driving and Regulations

The speed driven must be suited to the load transported and to official speed limits. In the absence of any speed limits, we recommend a maximum speed of 60 mph.

When transporting any load, the speed of the vehicle must take into account all conditions such as the state of the road, the surface of the road, traffic conditions, wind, etc. Vehicle handling, cornering, braking and sensitivity to side winds will change with the addition of roof top loads.

Off-road driving is not recommended and could result in damage to your vehicle or your bike.

Maintenance

The accessory rack should be carefully cleaned and maintained, particularly during the winter months. Use only a solution of water and standard car wash liquid without any alcohol, bleach or ammonium additives.

For reasons of fuel economy and the safety of other road users, the accessory rack and roof rack should be removed when not in use.

Periodically inspect accessory rack for damage. Replace lost, damaged or worn parts. Use only original spare parts obtained from a stocking specialist, dealer or manufacturer.

Any changes made to the roof racks and accessory racks as well as the use of spare parts or accessories other than those supplied by the manufacturer will lead to the lapsing of the manufacturer's warranty and liability for any material damage or accidents. You should observe these instructions to the letter and only use the original parts supplied.

In order to replace any lost or defective keys, note the lock and key numbers below and register them at www.whispbar.com.

Record Your Key Number:
(located on the set of
locking keys)

--	--	--	--

FR AVERTISSEMENTS IMPORTANTS

Pose du porte-bagage

Une charge mal arrimée, un porte-bagage de toit, ou encore un de ses accessoires, qui seraient mal installés pourraient se libérer en cours de trajet et provoquer un grave accident ! C'est pourquoi la pose, la manutention et l'utilisation de ce produit doivent être conformes aux instructions visant le produit et le véhicule.

En plus d'observer les présentes instructions, vérifier que les instructions visant la pose du porte-bagage et les instructions visant le véhicule.

Les présentes instructions devraient être jointes au manuel d'utilisation du véhicule et conservées à bord lors du déplacement.

Par sécurité, on ne devrait utiliser que des porte-bagages qui sont approuvés pour le véhicule.

Vérifier la solidité des dispositifs de fixation et l'arrimage de la charge :

- avant de prendre la route ;
- peu de temps après le départ si l'on a posé le porte-bagage ou si on l'a chargé ;
- à intervalles réguliers sur les longs trajets ;
- plus fréquemment sur routes cahoteuses ;
- après tout arrêt durant lequel le véhicule a été laissé sans surveillance (confirmer l'absence de dommages provoqués par des tiers).

Chargement du porte-bagage

Ne pas dépasser la charge maximale spécifiée pour le porte-bagage, l'accessoire de transport ou la charge maximale recommandée par le constructeur du véhicule.

Charge maximale sur le toit = poids du porte-bagage + poids de l'accessoire de transport + poids de la charge.

Aucune partie des bicyclettes, comme le guidon ou les pédales, ne doit dépasser au-delà du pourtour du véhicule.

Toutes les pièces lâches et amovibles des bicyclettes doivent être enlevées avant de charger les bicyclettes sur le porte-vélo.

Ne pas transporter de bicyclettes munies d'un siège de bébé, de sacoches, de housses de roues, d'une housse de vélo complète ou d'un moteur.

Ne pas transporter de tandems ou de vélos surbaissés ("recumbent")

Conduite du véhicule et réglementation

La vitesse à laquelle on roule doit tenir compte de la charge transportée et des limitations de vitesse. En l'absence de limitation de vitesse, nous recommandons de ne pas dépasser 130 km/h.

Quand on transporte n'importe quelle charge, la vitesse à laquelle on roule doit aussi tenir compte des conditions ambiantes comme l'état de la route, la surface de la route, les conditions de la circulation, le vent, etc. Le comportement du véhicule, sa tenue en virage, son freinage et sa sensibilité aux vents latéraux seront modifiés par l'addition de charges sur le toit.

La conduite hors route n'est pas recommandée car cela pourrait endommager le véhicule ou le vélo.

Entretien

L'accessoire de transport doit être nettoyé et entretenu avec soin, particulièrement durant l'hiver. Pour le nettoyage, n'employer que du savon liquide normal pour automobile et de l'eau, sans ajouter d'alcool, d'eau de Javel ou d'ammonium.

Pour économiser du carburant et par sécurité pour les autres usagers de la route, il est recommandé d'enlever l'accessoire de transport et le porte-bagage quand ils ne servent pas.

Inspecter l'accessoire de transport régulièrement. Remplacer les pièces perdues, endommagées ou usées. N'employer que des pièces d'origine, que l'on peut se procurer auprès d'un détaillant ou du fabricant.

Toute modification apportée au porte-bagage ou à l'accessoire de transport, ainsi que l'emploi de pièces ou d'accessoires autres que ceux fournis par le fabricant, annulerait la garantie et la responsabilité du fabricant en cas de dommages matériels ou d'accident. L'utilisateur doit donc respecter les présentes instructions à la lettre et n'employer que les pièces d'origine fournies.

Afin de pouvoir remplacer des clés perdues ou défectueuses, prendre note du numéro de la serrure et des clés ci-dessous et les enregistrer à www.whispbar.com.

Noter le numéro des clés :
(il se trouve sur les clés)

--	--	--	--

ES ADVERTENCIAS IMPORTANTES

Instalación del portaequipaje

¡Si las cargas no están aseguradas de manera adecuada y si los portaequipajes para techo y los portaequipajes adicionales están montados incorrectamente, se pueden aflojar durante un viaje y causar accidentes serios! Por lo tanto, la instalación, manipulación y uso se deben realizar respetando las instrucciones del producto y del vehículo.

Además de estas instrucciones, lea las instrucciones de montaje del portaequipaje para techo y las instrucciones de operación del vehículo.

Estas instrucciones se deben guardar junto con las instrucciones de operación del vehículo y llevar dentro del coche cuando este producto está instalado.

Para su propia seguridad, usted debe instalar solamente portaequipajes para techo aprobados para su vehículo.

Verifique los accesorios de fijación y la carga para asegurarse de que estén bien ajustadas y en buenas condiciones:

- Antes de salir de viaje.
- Una vez recorrida una corta distancia después de instalar el portaequipaje o la carga.
- A intervalos regulares durante los viajes más largos.
- Con más frecuencia en terrenos irregulares.
- Después de cada parada durante un viaje, en la que el vehículo quedó sin vigilancia (comprobación de daños debido a la posible acción de terceros).

Carga del portaequipaje

No exceda la carga máxima especificada para el portaequipaje para techo y de los portaequipajes adicionales, o la carga máxima recomendada por el fabricante del vehículo.

Carga máxima del techo = peso del portaequipaje para techo + peso de los portaequipajes adicionales + peso de la carga.

El portaequipaje para techo o el portaequipaje adicional no pueden sobrepasar las canaletas laterales del vehículo. Para vehículos sin esas canaletas, no deben sobrepasar los bordes laterales del techo. Consulte la StVZO (o a las reglamentaciones de su país).

Las piezas de la bicicleta, como el manillar o los pedales, no deben sobrepasar los contornos del vehículo.

Todas las piezas flojas y que se pueden desprender, se deben retirar de la bicicleta antes de cargarla sobre el portabicicleta.

No transporte bicicletas con asientos para bebés, cestas, protectores de rueda, cubrebicicletas o bicicletas con motor.

No transporte bicicletas en tándem o plegables.

Manejo del vehículo y reglamentaciones

Se debe conducir a una velocidad que tenga en cuenta la carga transportada y que respete los límites de velocidad reglamentarios. En caso de que el límite de velocidad no esté indicado, recomendamos no superar las 60 millas/h.

Cuando se transportan cargas sobre el techo, se debe circular a una velocidad que tenga en cuenta todas las condiciones circundantes, como el estado de la ruta, la superficie del camino, las condiciones del tráfico, el viento, etc. El manejo del vehículo, así como el frenado, agarre en las curvas y la influencia de los vientos de costado, cambian cuando se adicionan cargas sobre el techo.

Conducir fuera de las rutas no es recomendable porque se puede dañar el vehículo o la bicicleta.

Mantenimiento

El portaequipaje adicional se debe limpiar con cuidado y mantenerlo de manera adecuada, especialmente durante los meses de invierno. Para esto, utilice solamente una solución de agua y líquido lavacoche estándar, sin ningún añadido de alcohol, blanqueador o amoníaco.

Por razones de economía de combustible y de seguridad para otros usuarios de la carretera, el portaequipaje para techo y el portaequipaje adicional se deben desinstalar cuando no se utilizan.

Verifique periódicamente el portaequipaje adicional por si está dañado. Reemplace las piezas perdidas, rotas o gastadas. Utilice solamente repuestos de fábrica provenientes de un especialista, distribuidor o fabricante.

La modificación de los portaequipajes para techo y de los adicionales, así como el uso de otras piezas de repuesto o accesorios diferentes de los provistos por el fabricante, harán caducar la garantía y la responsabilidad del fabricante por daños materiales o accidentes. Usted debe respetar al pie de la letra estas instrucciones de uso y utilizar solamente las piezas de origen provistas.

Para reemplazar una llave perdida o defectuosa, anote más abajo los números de la cerradura y de la llave y regístrelos en www.whispbar.com.

Anote el número de su llave:
(grabado en las llaves de
bloqueo)

--	--	--	--

Limited Lifetime Warranty

**Technical Assistance or Replacement Parts: Contact your dealer or visit
www.whispbar.com or call (888) 925-4621 Monday through Friday, 7:00am to 5:00pm, PST**

LIMITED LIFETIME WARRANTY

This limited lifetime warranty covers all Whispbar-brand products* and rack components manufactured by Yakima Products, Inc. (Yakima), and is effective for as long as the original retail purchaser owns the product. This warranty terminates when the original retail purchaser sells or otherwise transfers the product to any other person.

Subject to Yakima's inspection of the product, Yakima will remedy defects in materials and/or workmanship by repairing or replacing, at Yakima's option, the defective product without charge for parts or labor, subject to the limitations and exclusions described in this warranty. Yakima may elect, at its option, not to repair or replace a defective product, in which case Yakima will issue to the original retail purchaser, at Yakima's option, either a refund equal to the purchase price paid for the product, or a credit to be used toward the purchase of new Whispbar products or rack components.

This warranty does not cover problems caused by normal wear and tear (including, but not limited to, scratches, dents, tears, or aesthetic oxidation of surfaces, or natural breakdown of colors and materials over extended time and use), commercial use, accidents, unlawful vehicle operation, or modifications or repairs not performed or authorized by Yakima.

In addition, this warranty does not cover problems resulting from conditions beyond Yakima's control including, but not limited to, theft, misuse, overloading, or failure to assemble, mount or use the product in accordance with Yakima's written instructions or guidelines included with the product or made available to the original retail purchaser.

If a product is believed to be defective, the original retail purchaser should contact the Whispbar dealer from whom it purchased the product, who will give the original retail purchaser instructions on how to proceed. If the original retail purchaser is unable to contact the Whispbar dealer, or the dealer is not able to remedy the defect, the original retail purchaser should contact Yakima by e-mail at: yakwarranty@yakima.com, or phone 888.925.4621 for shipping instructions.

Upon contacting Yakima directly, a Yakima technician will provide the original retail purchaser with appropriate instructions for returning the product to Yakima. The original retail purchaser will be responsible for the cost of mailing the product to Yakima. In order to receive any remedy under this warranty (either from a Whispbar dealer, or from Yakima directly), proof of purchase in the form of an original purchase invoice or receipt is strictly required.

LIMITATION OF LIABILITY

REPAIR OR REPLACEMENT OF A DEFECTIVE PRODUCT, OR THE ISSUANCE OF A REFUND OR CREDIT (AS DETERMINED BY YAKIMA), IS THE ORIGINAL RETAIL PURCHASER'S EXCLUSIVE REMEDY UNDER THIS WARRANTY. DAMAGE OR INJURY TO THE ORIGINAL RETAIL PURCHASER, TO HIS OR HER VEHICLE, CARGO, OR PROPERTY, AND/OR TO ANY OTHER PERSON OR PROPERTY IS NOT COVERED BY THIS WARRANTY. THIS WARRANTY IS EXPRESSLY MADE IN LIEU OF ANY AND ALL OTHER EXPRESS WARRANTIES, WHETHER ORAL OR WRITTEN.

YAKIMA'S SOLE LIABILITY IS LIMITED TO THE REMEDY SET FORTH ABOVE. IN NO EVENT WILL YAKIMA BE LIABLE FOR ANY DIRECT, INDIRECT, CONSEQUENTIAL, INCIDENTAL, SPECIAL, EXEMPLARY, OR PUNITIVE DAMAGES OR FOR ANY OTHER DAMAGES OF ANY KIND OR NATURE (INCLUDING, BUT NOT LIMITED TO, LOST PROFITS OR LOST SALES). SOME STATES DO NOT ALLOW THE EXCLUSION OR LIMITATION OF INCIDENTAL OR CONSEQUENTIAL DAMAGES, SO THE ABOVE LIMITATIONS MAY NOT APPLY TO YOU. THIS WARRANTY GIVES YOU SPECIFIC LEGAL RIGHTS, AND YOU MAY ALSO HAVE OTHER RIGHTS WHICH VARY FROM STATE TO STATE.

Limited Lifetime Warranty & Disclaimer (AU / NZ)

**Yakima Australia Pty Ltd ABN 58 154 440 221
17 Hinkler Court, Brendale QLD 4500
Tel: 0800 4776 722 (NZ) or 1800 143 548 (AU)
Email: warranty@yakima.co.nz or warranty@yakima.com.au**

1. Where the product is supplied to the customer for other than business purposes within the meaning of section 43 of the New Zealand Consumer Guarantees Act 1993, the provisions of that Act shall apply. It is important that anyone who fits or uses this product does so in accordance with the manufacturer's instructions.
2. Where the product is supplied to the customer for business purposes within the meaning of section 43 of the New Zealand Consumer Guarantees Act 1993, the provisions of that Act and all other representations or terms (including any conditions or warranty expressed or implied by law, statute or otherwise) not expressly included in this leaflet are hereby expressly excluded shall have no effect and the clauses (a) and (b) shall apply.
3. Subject to the Additional Information (Australia), where the product is supplied and purchased in Australia, the following shall apply:
 - (a). **THE SUPPLIER WARRANTS** the product to be free from defects in materials and/or workmanship for the lifetime of the product (the warranty period), subject to the limitations and exclusions set out below and is effective for as long as the original retail purchaser owns the product. This warranty terminates when the original retail purchaser sells or otherwise transfers the product to any other person. Proof of purchase is required. The Supplier hereby agrees to remedy any defects in materials or workmanship becoming apparent during the warranty period, by replacing or repairing any defective product or component (at its option) free of charge to the purchaser in respect of replacement parts or labour. Any defective product or component must be notified and where practicable, returned at the purchaser's expense to the Supplier immediately upon discovery of the alleged defect and no attempt made on the part of the purchaser to repair it.
 - (b). **EXCEPTIONS, EXCLUSIONS AND LIMITATIONS TO WARRANTY.** The product and/or its components must be fitted/assembled and loaded in accordance with the Supplier's written instructions and any requirements set out in the car's owner manual. This warranty does not cover defects, loss or damage resulting from circumstances beyond the Supplier's control including, but not limited to misuse, overloading, or failure to assemble and/or fit the product or component in accordance with the Supplier's written instructions. Nor does the warranty cover defects, loss or damage resulting from accidents, unlawful use of the vehicle or defects/inconsistencies in the vehicle on which the product or component is fitted. Liability for direct, indirect, special, punitive, incidental, exemplary, contractual or consequential damage or loss arising from defects, faulty materials or design omissions or negligence or workmanship in the product or its components is hereby expressly excluded subject to the following. Certain Commonwealth legislation, including the Competition and Consumer Act 2010 (Cth), and other State and Territorial legislation confers upon purchasers rights which cannot be excluded from or be restricted or modified by contract. Any conditions, guarantees and/or warranties implied by law and incapable of exclusion are deemed to be expressly incorporated herein. Nothing herein contained is intended nor shall be permitted to be inconsistent with any such conditions, guarantees and/or warranties. To the extent permitted by legislation all conditions, guarantees and/or warranties such as implied warranties which are capable of exclusion are hereby expressly excluded and negated.

Additional Information (AU / NZ)

This information should be read in conjunction with clauses (a) and (b).

IMPORTANT LEGAL NOTICE

Our goods come with guarantees that cannot be excluded under the Australian Consumer Law. You are entitled to a replacement or refund for a major failure and for compensation for any other reasonably foreseeable loss or damage. You are also entitled to have the goods repaired or replaced if the goods fail to be of acceptable quality and the failure does not amount to a major failure.

This warranty does not change or take away your rights under the Australian Consumer Law. Your right to claim under this policy for the benefits covered is in addition to other rights and remedies you have under the law in relation to the product.

Where you become aware of defects in materials or of workmanship, and wish to make a claim under this warranty you must do the following for the warranty to be honoured by your Whipbar dealer or Yakima Australia Pty Ltd ABN 58 154 440 221 (Yakima):

1. Make a claim as soon as practicable by contacting the Whipbar dealer from whom you purchased the product, who will give you instructions on how to proceed.
2. If you are unable to contact the Whipbar dealer, or the dealer is not able to remedy the defect, you should contact Yakima as soon as practicable at:

Call: 0800 4776 722 (NZ) or 1800 143 548 (AU)
Email: warranty@yakima.co.nz or warranty@yakima.com.au

Alternately, you can write to Yakima at 17 Hinkler Court, Brendale QLD Australia 4500 in order to make a claim under your warranty.

3. Upon contacting Yakima directly, you should explain as fully as possible the defect. A Yakima representative will provide you with appropriate instructions for returning the product together with a copy of the original purchase invoice or receipt to Yakima.
4. The costs and expenses associated with making a claim under your warranty including the costs of complying with those instructions and of returning the product to Yakima or the Whipbar dealer will be borne by you.

Following receipt of the product and purchase invoice or receipt, Yakima or the Whipbar dealer must inspect the product to determine whether the claim falls within the warranty. If:

- 4.1 the claim falls within the warranty, Yakima will remedy any defects in materials or workmanship becoming apparent during the warranty period, by replacing or repairing any defective product or component (at its option) free of charge to the purchaser in respect of replacement parts or labour.
- 4.2 the claim does not fall within the warranty, Yakima will return the product to you at your expense.

Garantie Limitée À Vie

POUR OBTENIR DES RENSEIGNEMENTS TECHNIQUES OU DES PIÈCES DE RECHANGE prière de contacter votre dépositaire, de consulter le site www.whipbar.com ou d'appeler au (888) 925-4621, du lundi au vendredi, entre 7 heures et 17 heures, heure du Pacifique.

GARANTIE LIMITÉE À VIE

La présente garantie à vie limitée couvre tous les produits* et composantes de porte-bagage de marque Whipbar fabriqués par Yakima Products, Inc. (Yakima), et demeure en vigueur tant que l'acheteur au détail d'origine est propriétaire du produit. Cette garantie prend fin quand l'acheteur au détail d'origine vend ou cède d'une autre façon le produit à une autre personne.

Sous réserve de l'inspection du produit par Yakima et des limitations et exclusions décrites ici, Yakima corrigera les vices de matériau ou de fabrication en réparant ou en remplaçant, au choix de Yakima, le produit défectueux sans frais pour les pièces ou la main d'œuvre. Yakima peut décider, à sa discrétion, de ne pas réparer ou remplacer le produit défectueux ; dans ce cas Yakima remettra à l'acheteur au détail d'origine, à la discrétion de Yakima, soit un remboursement correspondant au prix d'achat du produit, soit un crédit applicable à l'achat de produits ou de composantes de porte-bagage Whipbar neufs.

Cette garantie ne couvre pas l'usure normale (comme entre autres les égratignures, les bosses, les déchirures ou l'oxydation superficielle, ou la dégradation naturelle des couleurs ou des matériaux causée par le temps et une utilisation prolongée), l'utilisation commerciale ou les dommages résultant d'un accident, de l'utilisation illégale du véhicule ou de modifications ou réparations non exécutées ou autorisées par Yakima.

De plus, cette garantie ne couvre pas les dommages consécutifs à des situations sur lesquelles Whipbar n'a aucun contrôle, comme, entre autres, le vol, une mauvaise utilisation et la surcharge, ou consécutifs à un assemblage, une installation ou une utilisation du produit ne correspondant pas aux instructions écrites de Yakima fournies avec le produit ou communiquées à l'acheteur au détail d'origine.

S'il estime que son produit Yakima est défectueux, l'acheteur au détail d'origine doit s'adresser au dépositaire Yakima chez qui le produit a été acheté ; celui-ci indiquera au client comment procéder. Si l'acheteur au détail d'origine ne peut communiquer avec le dépositaire Whipbar, ou si le dépositaire ne peut corriger le défaut, l'acheteur au détail d'origine doit communiquer avec Yakima par courriel à : yakwarranty@yakima.com, ou par téléphone au (888) 925-4621 pour obtenir des instructions d'expédition.

Si l'acheteur au détail d'origine contacte Yakima directement, un technicien de Yakima lui indiquera la manière de retourner le produit à Yakima. L'acheteur au détail d'origine devra assumer les frais de transport jusqu'à Yakima. Afin de pouvoir se prévaloir de cette garantie (soit d'un dépositaire Whipbar, soit directement de Yakima), il est obligatoire de présenter une preuve d'achat, sous forme soit de la facture originale soit du reçu original.

LIMITATION DE RESPONSABILITÉ

LA RÉPARATION OU LE REMPLACEMENT D'UN PRODUIT DÉFECTUEUX, OU ENCORE LA DÉLIVRANCE D'UN REMBOURSEMENT OU D'UN AVOIR (À LA DISCRÉTION DE YAKIMA), CONSTITUE LE RECOURS EXCLUSIF DE L'ACHETEUR AU DÉTAIL ORIGINAL TOUT AU LONG DE LA DURÉE DE VALIDITÉ DE CETTE GARANTIE. TOUT DOMMAGE OU TOUTE BLESSURE INFLIGÉ(E) À L'ACHETEUR AU DÉTAIL ORIGINAL, À SON VÉHICULE, À SON CHARGEMENT, OU À SA PROPRIÉTÉ, ET/OU À TOUTE AUTRE PERSONNE OU À TOUTE AUTRE PROPRIÉTÉ, N'EST PAS COUVERT PAR CETTE GARANTIE. CETTE GARANTIE EST EXPRESSÉMENT FAITE POUR REMPLACER TOUTE AUTRE GARANTIE EXPRESSE, QU'ELLE SOIT ORALE OU ÉCRITE. LA SEULE RESPONSABILITÉ DE YAKIMA EST LIMITÉE AU RECOURS DÉVELOPPÉ CI-DESSUS. EN AUCUN CAS, YAKIMA NE POURRA ÊTRE TENUE POUR RESPONSABLE DES DOMMAGES DIRECTS, INDIRECTS, CONSÉQUENTS, EXEMPLAIRES OU PUNITIFS OU DE TOUT AUTRE DOMMAGE DE QUELQUE NATURE QUE CE SOIT (Y COMPRIS, ENTRE AUTRES, DE MANQUES À GAGNER OU DE VENTES MANQUÉES).

Garantía Limitada a Vida

SI NECESITA ASISTENCIA TÉCNICA O REPUESTOS Contacte un vendedor, visite el sitio www.whispbar.com o llame al (888)925-4621 De lunes a viernes, 7:00 AM a 5:00 PM, hora del Pacífico

GARANTÍA LIMITADA DE POR VIDA

Esta garantía limitada a vida cubre todos los productos* y componentes de montaje de marca Whispbar, fabricados por Yakima Products, Inc. (Yakima), y es válida durante todo el tiempo que el comprador original conserve el producto. La validez de esta garantía caduca cuando el comprador original vende o transfiere el producto a otra persona.

Sujeto a la inspección de Yakima™ y a las limitaciones y exclusiones descritas en esta garantía, Yakima reparará o reemplazará, a su criterio, el producto que presente defectos de material y/o mano de obra, según lo crea conveniente, y sin costo por las piezas o el trabajo que esto suponga. Yakima puede decidir, según lo estime conveniente, no reparar o reemplazar un producto defectuoso. En tal caso, Yakima™ otorgará al comprador original, a su criterio, ya sea un reembolso igual al precio de compra o un crédito para ser usado en la compra de nuevos productos o componentes de montaje Whispbar.

Esta garantía no cubre problemas causados por uso o desgaste normal del producto (incluyendo, a modo enunciativo pero no limitativo, rayones, abolladuras, u oxidaciones que afectan sólo la apariencia de las superficies), accidentes, uso ilegal del vehículo, reparaciones o modificaciones no realizadas o autorizadas por Yakima.

Esta garantía no cubre los problemas causados por el uso y desgaste normal del producto (incluyendo, a modo enunciativo pero no limitativo, raspones, abolladuras, rajaduras u oxidaciones que afectan sólo la apariencia de las superficies, o la degradación natural de los colores y materiales con el tiempo y el uso prolongado), uso comercial, accidentes, uso indebido del vehículo, reparaciones o modificaciones no realizadas o no autorizadas por Yakima.

Si el comprador original considera que un producto tiene algún defecto, puede comunicarse con el concesionario de productos Whispbar donde adquirió el producto, quien le entregará las instrucciones necesarias sobre cómo proceder en este caso. Si no es posible comunicarse con el concesionario, o éste no puede reparar el defecto, el comprador original deberá comunicarse con Yakima por correo electrónico, escribiendo a yakwarranty@yakima.com o llamando al 888 925 4621 para recibir las instrucciones de envío del producto.

Al comunicarse directamente con Yakima, un técnico de Yakima entregará las instrucciones apropiadas al comprador original para devolver el producto a Yakima. El comprador original se debe hacer cargo de los gastos de envío. Para recibir un servicio de reparación cubierto por esta garantía (tanto del concesionario de los productos Whispbar como directamente de Yakima) se exigirá sin excepción el original de la factura o del recibo.

LIMITACIÓN DE LA RESPONSABILIDAD

LA REPARACIÓN O SUSTITUCIÓN DEL PRODUCTO DEFECTUOSO O LA EMISIÓN DE UN REEMBOLSO O UN VALE (SEGÚN LO DETERMINE YAKIMA), CONSTITUYEN EL REMEDIO EXCLUSIVO PARA EL COMPRADOR ORIGINAL EN VIRTUD DE ESTA GARANTÍA. LOS DAÑOS O LESIONES OCASIONADOS AL COMPRADOR ORIGINAL, A SU VEHÍCULO, CARGA O PROPIEDAD O A CUALQUIER PERSONA O PROPIEDAD NO ESTÁN CUBIERTOS POR ESTA GARANTÍA. ESTA GARANTÍA ESTÁ CONCEBIDA EXPRESAMENTE PARA REEMPLAZAR AL RESTO DE GARANTÍAS, SEAN ORALES O ESCRITAS. LA RESPONSABILIDAD DE YAKIMA SE LIMITA AL REMEDIO MENCIONADO ANTERIORMENTE. EN NINGÚN CASO, YAKIMA SERÁ RESPONSABLE DE DAÑO ALGUNO DIRECTO, INDIRECTO, INCIDENTAL, ESPECIAL, PUNITIVO U OTROS DAÑOS DE CUALQUIER NATURALEZA (INCLUYENDO, SIN LIMITARSE A ELLO, GANANCIAS O VENTAS NO REALIZADAS).

PRODUCT COMPATIBILITY • COMPATIBILITÉ DU PRODUIT • COMPATIBILIDAD DEL PRODUCTO

This product is intended for use with Whispbar rack systems using QuickDock technology. It also works with other original and aftermarket roof rack systems.

- Check the compatibility of QuickDock with other manufacturers roof racks at: whispbar.com/quickdock

Ce produit est conçu pour être monté sur les porte-bagages Whispbar grâce à la technologie QuickDock. Il fonctionne aussi avec d'autres porte-bagages, d'origine et vendus comme accessoires.

- Pour vérifier la compatibilité du système QuickDock avec les porte-bagages d'autres fabricants, consulter le site : whispbar.com/quickdock

Este producto está diseñado para los sistemas de racks Whispbar empleando la tecnología QuickDock. También es compatible con otros sistemas de racks para techos de origen o que se encuentran en el mercado de accesorios.

- Verifique la compatibilidad de QuickDock con otros racks para techos de origen en: whispbar.com/quickdock



YAKIMA AUSTRALIA PTY. LTD

17 Hinkler Court
Brendale
QLD 4500
Brisbane
Australia
1800-143-548

YAKIMA PRODUCTS, INC.

15025 SW Koll Pkwy
Beaverton, OR 97006
USA
888-925-4621

YAKIMA EUROPE

Archimedesbaan 25
3439 ME Nieuwegein
The Netherlands